

MAL NO.-17526

D7349

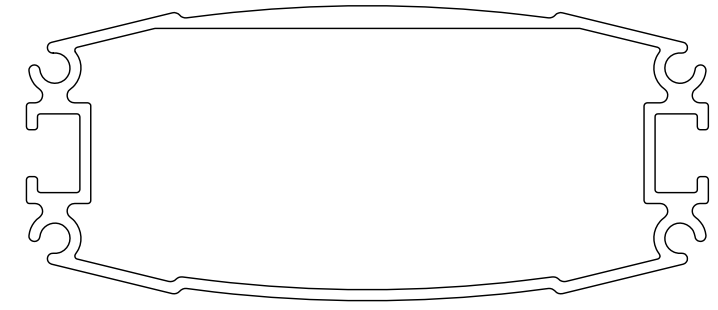

SCALE 1:1

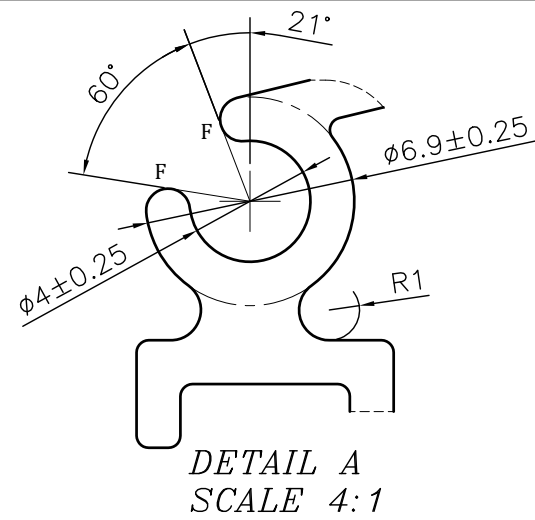
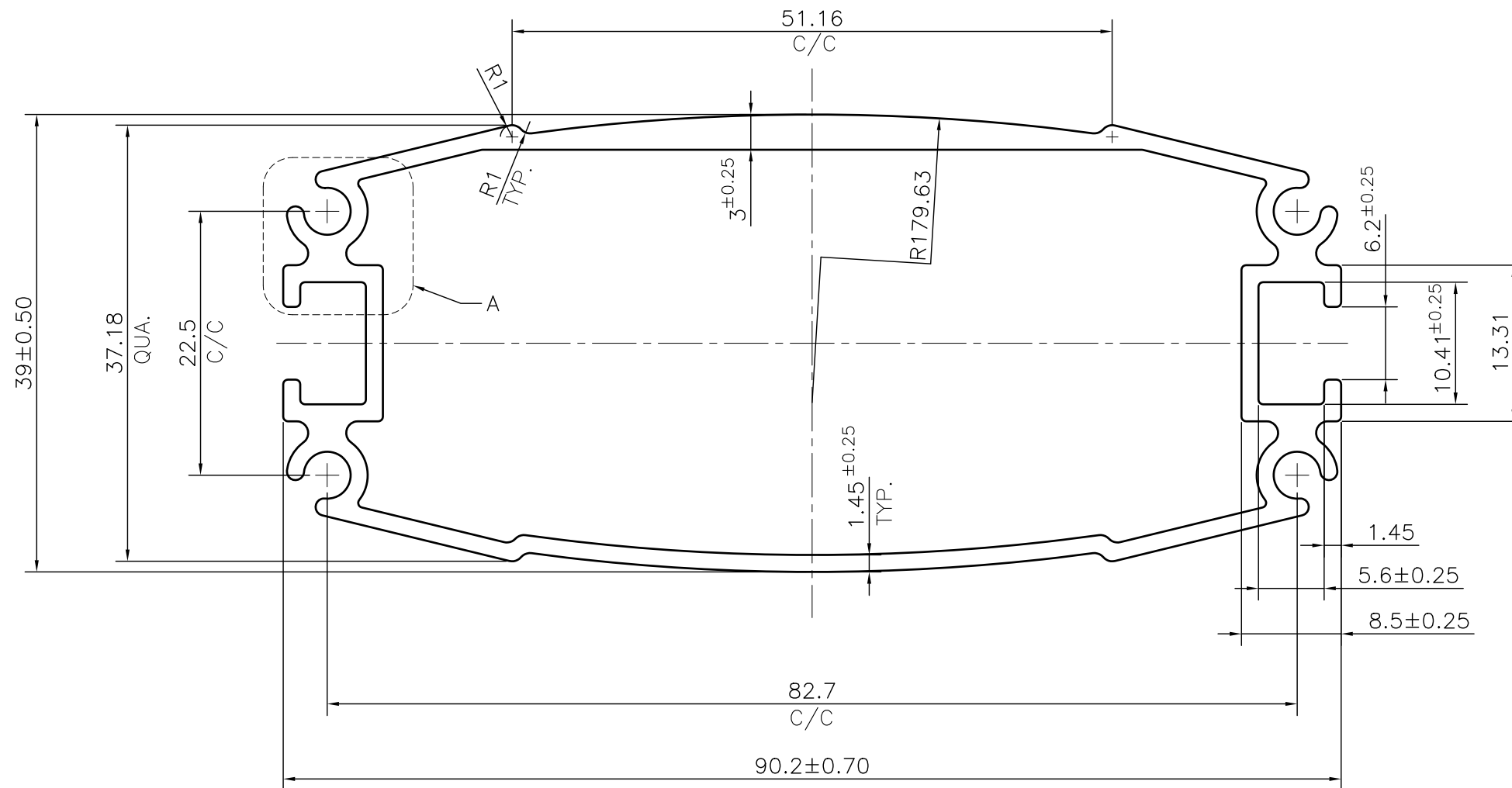

NOTE:-
F= FULL RADIUS (8 PLACES)

1. STRAIGHTNESS= 1.7mm/M
2. TWIST= 1.7mm/M
3. ANGULARITY= $\pm 2^\circ$
4. FLATNESS= 0.007xWIDTH

 SYMBOL OF QUALITY AN ISO 9001 COMPANY	JINDAL ALUMINIUM LTD. BHIWADI-301019 (INDIA)		NAME	DATE
			DRAWN	ASHUTOSH 15-04-2024
1. ALL DIMENSIONS ARE IN mm. 2. ROUND OFF ALL SHARP CORNERS WITH 0.40 mm. 3. TOLERANCES WILL BE AS PER BS:EN-755-9 , UNLESS OTHERWISE SPECIFIED			CHECKED	
			APPROVED	
PARTY'S NAME SIDHARTH STEELS & GLASS INDUSTRIES			SCALE	2:1
			AREA mm ²	478.334
PARTY'S DRAWING No. AS PER DRAWING			PERIMETER mm.	319.739
			WEIGHT kg/m	1.292
ALLOY & TEMPER 6063 T6			DRAWING No.	SECTION No.
			MAL NO.-17526	-
DESCRIPTION ARCHITECTURAL MISC. SECTION			D7349	D7349
			PRODUCT CODE:-056	
			HSN CODE:- 76042100	