

JAL-B-026

-

D-7519

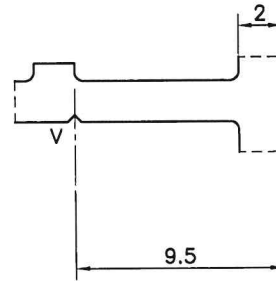

DETAIL A
SCALE 4:1

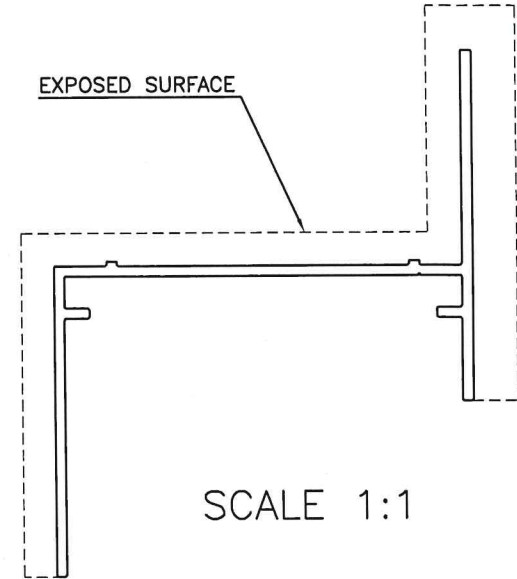

SCALE 1:1

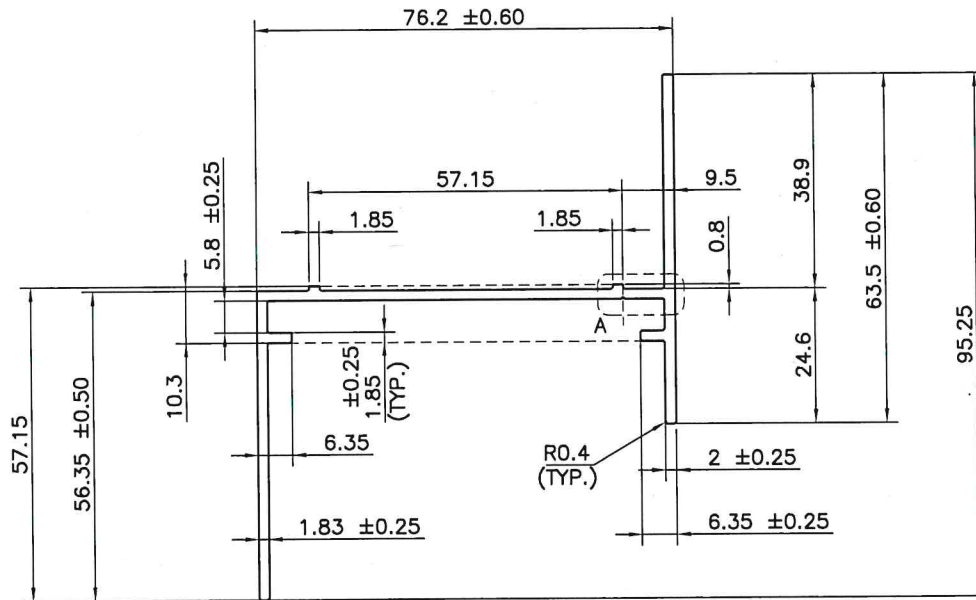

NOTE:-

V- (0.3x90°) V-GROOVE



SYMBOL OF QUALITY
AN ISO 9001 COMPANY

JINDAL ALUMINIUM LTD.
BANGALORE-560073 (INDIA)

1. ALL DIMENSIONS ARE IN mm.
2. ROUND OFF ALL SHARP CORNERS WITH 0.40 mm.
3. TOLERANCES WILL BE AS PER BS:EN-755-9 , UNLESS OTHERWISE SPECIFIED

		NAME	DATE
DRAWN	ASHUTOSH		15.07.2022
CHECKED	<i>Junit</i>		22.7.22
APPROVED	<i>May</i>		21.07.22
SCALE		1:1	
AREA mm ²		383.49	
PERIMETER mm.		405.44	
WEIGHT kg/m		1.035	
PARTY'S NAME	M/S. RUSKIN AIR & SOUND CONTROL	DRAWING No.	SECTION No.
PARTY'S DRAWING No.	AS PER DRAWING- (70-022826-00B)	JAL-B-026	D-7519
ALLOY & TEMPER	6063-T6	-	-
DESCRIPTION	-	-	-