

P-JAL-B-033-1

D-7525

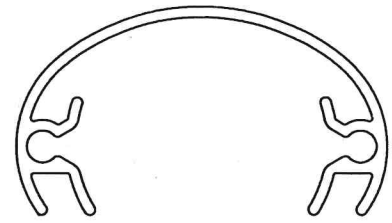

SCALE 1:1

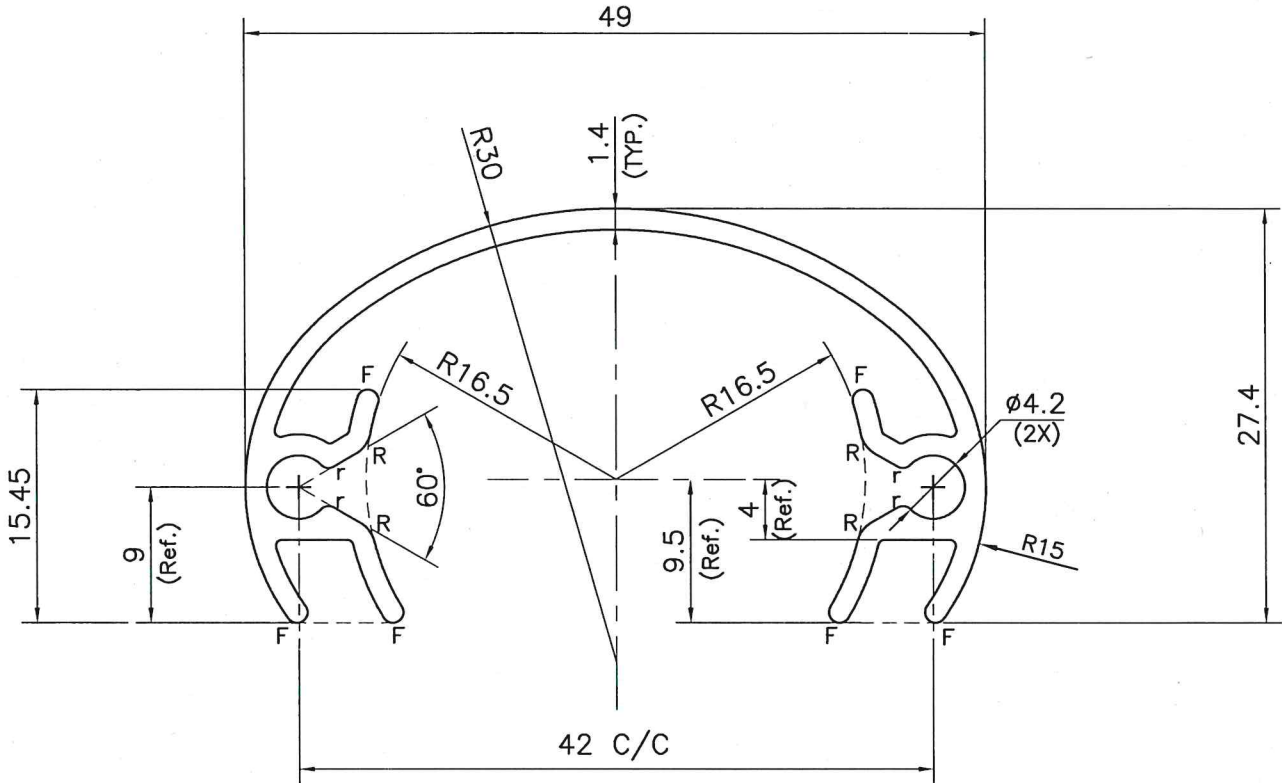

NOTE:-

r= 0.70R

R= 2.00R

F= FULL RADIUS

Revision:-

A. Drawing has been revised as per customer CAD Drawing



SYMBOL OF QUALITY
AN ISO 9001 COMPANY

JINDAL ALUMINIUM LTD.
BHIWADI-301019 (INDIA)

1. ALL DIMENSIONS ARE IN mm.
2. ROUND OFF ALL SHARP CORNERS WITH 0.40 mm.
3. TOLERANCES WILL BE AS PER BS:EN-755-9 , UNLESS OTHERWISE SPECIFIED

		NAME	DATE
DRAWN		ASHUTOSH	31-10-2022
CHECKED		<i>[Signature]</i>	4-11-22
APPROVED		<i>[Signature]</i>	04.11.22
SCALE		1:1&2:1	
AREA mm ²		184.57	
PERIMETER mm.		253.06	
WEIGHT kg/m		0.498	
DRAWING No.		SECTION No.	
P-JAL-B-033-1		D-7525	
D-7525			
ALLOY & TEMPER		6063-T6	
DESCRIPTION		--	
PARTY'S NAME		M/S. ANTARCTICA EQUIPMENTS	
PARTY'S DRAWING No.		AS PER DRAWING (EXT-12452-01)	