

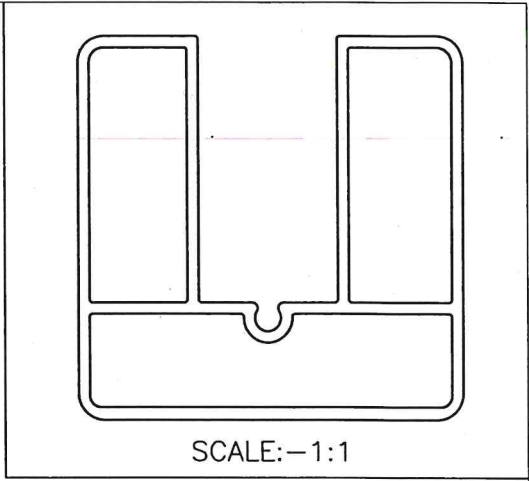

P-JAL-B-042-1  
 -  
 D-7527

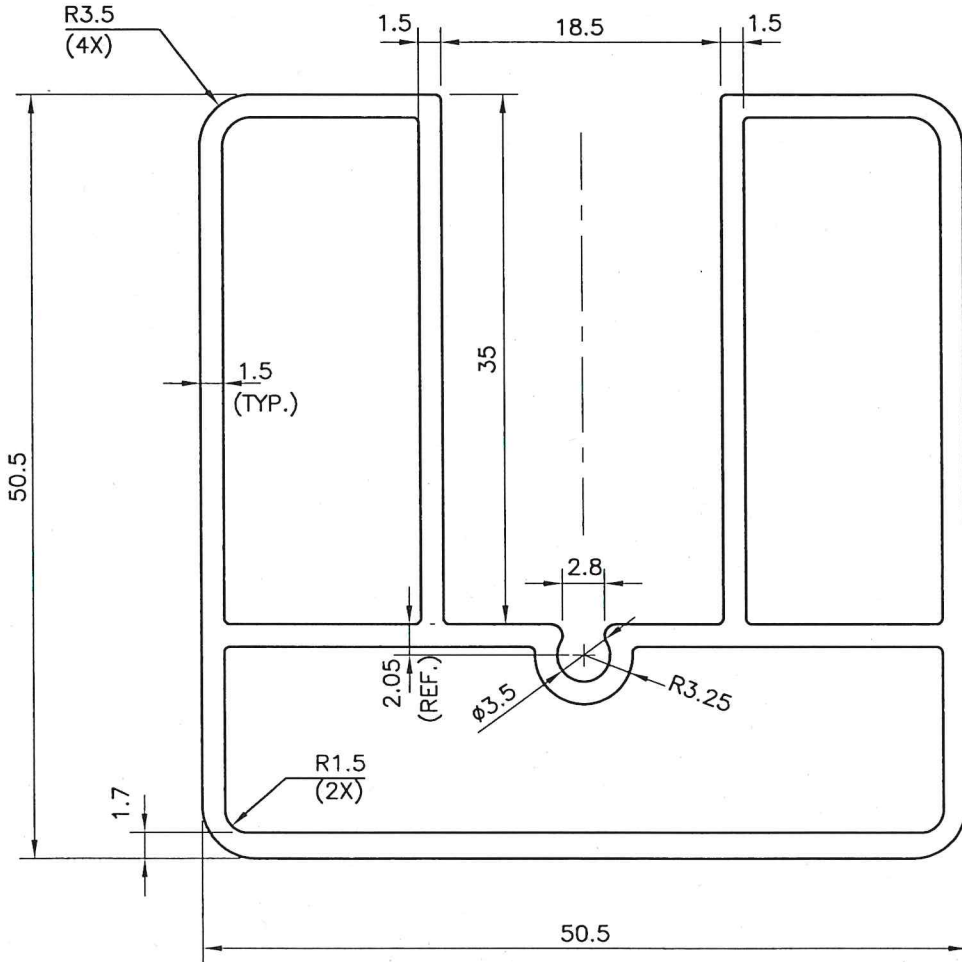

SCALE:-1:1



NOTE:-  
 A. Drawing has been revised as per customer reference.

 SYMBOL OF QUALITY AN ISO 9001 COMPANY	<b>JINDAL ALUMINIUM LTD.</b> BHIWADI-301019 (INDIA)	NAME	DATE
		DRAWN	ASHUTOSH 05-11-2022
		CHECKED	Amal 2/11/22
		APPROVED	Ma 07.11.22
1. ALL DIMENSIONS ARE IN mm. 2. ROUND OFF ALL SHARP CORNERS WITH 0.40 mm. 3. TOLERANCES WILL BE AS PER BS:EN-755-9 , UNLESS OTHERWISE SPECIFIED		SCALE	1:1&2:1
PARTY'S NAME		AREA mm <sup>2</sup>	448.86
M/S ALUMINIUM TRADING COMPANY, NEW DELHI		PERIMETER mm.	271.57
		WEIGHT kg/m	1.212
PARTY'S DRAWING No.	AS PER SAMPLE	DRAWING No.	SECTION No.
ALLOY & TEMPER	6063-T6	P-JAL-B-042-1	D-7527
DESCRIPTION	--		