

P-JAL-B-056-1

D-7536

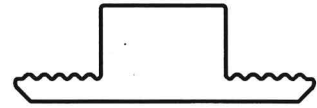

SCALE 1:1

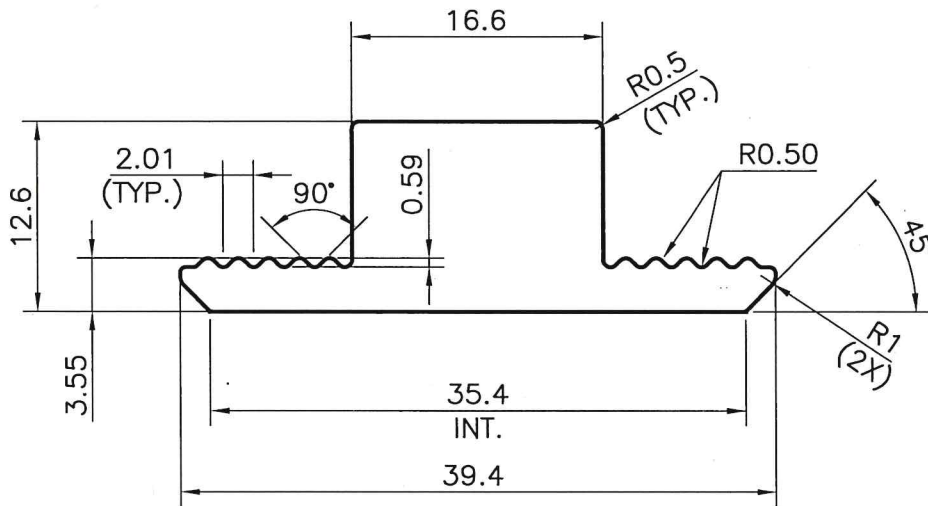

ISSUE-2:-

- (1) Date: 16.02.2023-
Drawing has been Revised

NOTE:-

- (A) Drawing has been revised as per customer CAD Drawing



SYMBOL OF QUALITY
AN ISO 9001 COMPANY

JINDAL ALUMINIUM LTD.
BHIWADI-301019 (INDIA)

	NAME	DATE
DRAWN	ASHUTOSH	17-11-2022
CHECKED	<i>[Signature]</i>	24.2.23
APPROVED	<i>[Signature]</i>	24/02/23
SCALE		1:1&2:1
AREA mm ²		278.45
PERIMETER mm.		104.35
WEIGHT kg/m		0.752
DRAWING No.		SECTION No.
P-JAL-B-056-1		D-7536
		ISSUE-2

- ALL DIMENSIONS ARE IN mm.
- ROUND OFF ALL SHARP CORNERS WITH 0.40 mm.
- TOLERANCES WILL BE AS PER BS:EN-755-9 , UNLESS OTHERWISE SPECIFIED

PARTY'S NAME	M/s. ALTOS ENGINEERS
PARTY'S DRAWING No.	AS PER DRAWING (Q00183)
ALLOY & TEMPER	6005-T6
DESCRIPTION	--