

P-JAL-B-060-1

D-7540

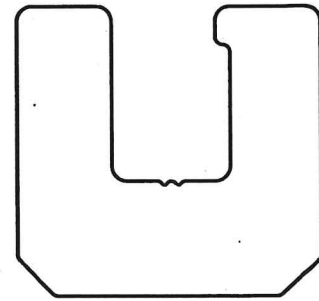

SCALE 1:1

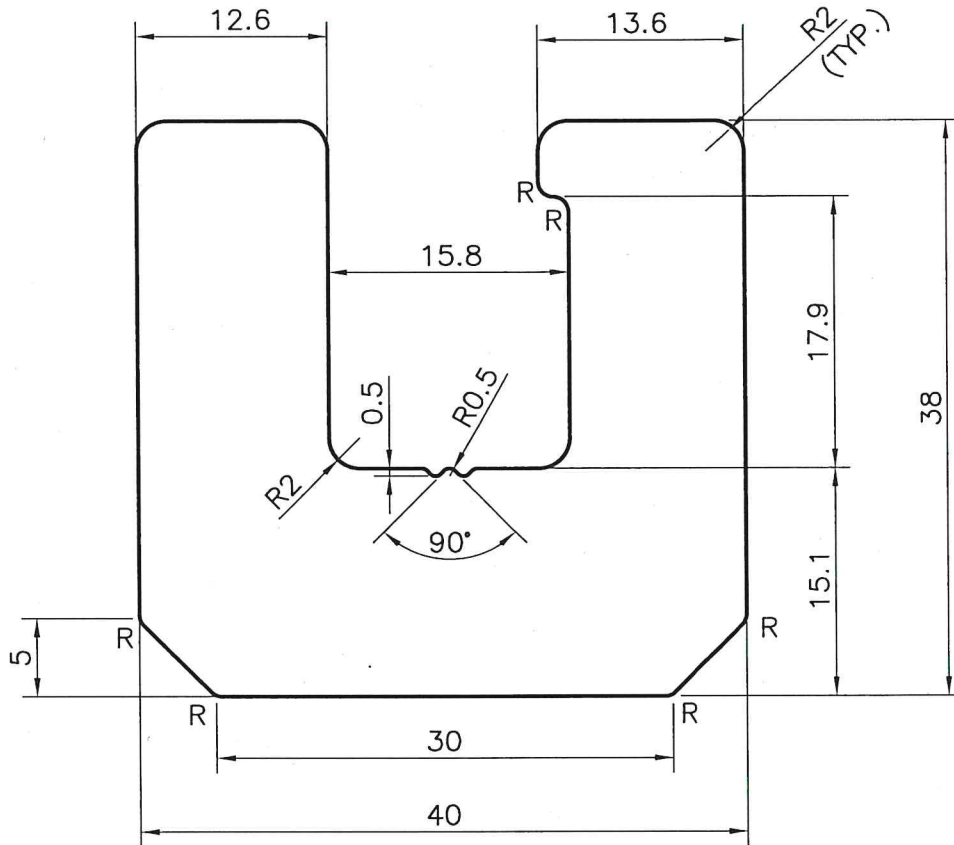

NOTE:-  
R= 1.00R

NOTE:-

(A) Drawing has been revised as per customer CAD Drawing



SYMBOL OF QUALITY  
AN ISO 9001 COMPANY

**JINDAL ALUMINIUM LTD.**  
BHIWADI-301019 (INDIA)

	NAME	DATE
DRAWN	ASHUTOSH	22-11-2022
CHECKED	<i>Junit</i>	3-12-22
APPROVED	<i>Jhan</i>	03-12-22

1. ALL DIMENSIONS ARE IN mm.
2. ROUND OFF ALL SHARP CORNERS WITH 0.40 mm.
3. TOLERANCES WILL BE AS PER BS:EN-755-9 , UNLESS OTHERWISE SPECIFIED

SCALE	1:1&2:1
AREA mm <sup>2</sup>	1140.46
PERIMETER mm.	194.42
WEIGHT kg/m	3.079
DRAWING No.	SECTION No.
P-JAL-B-060-1	D-7540

PARTY'S NAME M/s. ALTOS ENGINEERS

PARTY'S DRAWING No. AS PER DRAWING (Q00187)

ALLOY & TEMPER 6005-T6

DESCRIPTION --