

P-JAL-B-064

D-7541

ISSUE-2:-

- (A) DATE:15.03.2023-DIM 2.8 WAS 3.5mm
- (B) DATE:15.03.2023-DIM 5.9 WAS 5.5mm
- (C) DATE:15.03.2023-DIM 4.5 WAS 5.0mm
- (D) DATE:15.03.2023-DIM 7.2 WAS 8.0mm
- (E) DATE:20.03.2023-DIM 14.2 WAS 15.5mm

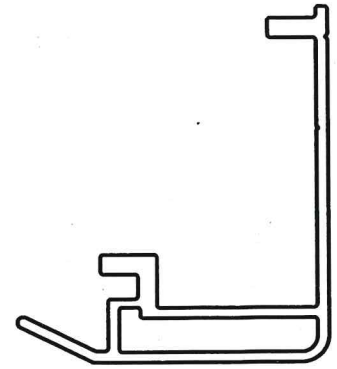

SCALE 1:1

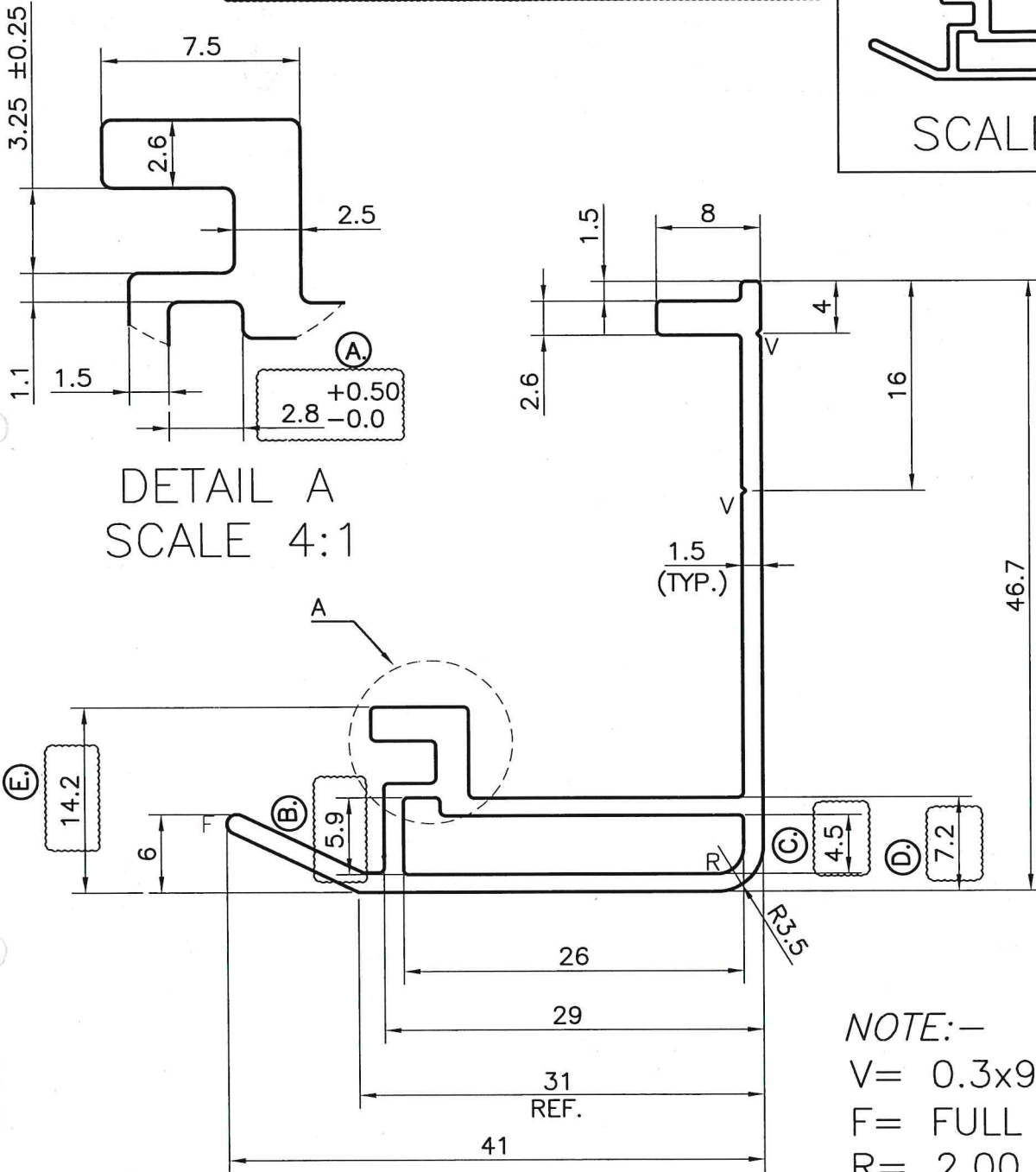

DETAIL A
SCALE 4:1

NOTE:-

V = 0.3x90°

F = FULL RADIUS

R = 2.00 RADIUS



SYMBOL OF QUALITY
AN ISO 9001 COMPANY

JINDAL ALUMINIUM LTD.

BHIWADI-301019 (INDIA)

	NAME	DATE
DRAWN	ASHUTOSH	18-10-2022
CHECKED	<i>Junil</i>	22/3/23
APPROVED	<i>Jha</i>	22/03/23
SCALE	1:1&2:1	
AREA	mm ²	216.54
PERIMETER	mm.	210.21
WEIGHT	kg/m	0.585
DRAWING No.	SECTION No.	
P-JAL-B-064	D-7541	
D-7541	ISSUE-2	

1. ALL DIMENSIONS ARE IN mm.
2. ROUND OFF ALL SHARP CORNERS WITH 0.40 mm.
3. TOLERANCES WILL BE AS PER BS:EN-755-9 , UNLESS OTHERWISE SPECIFIED

PARTY'S NAME M/s. UNIQUE MEDICAL EQUIPMENTS PVT. LTD.

PARTY'S DRAWING No. AS PER EMAIL (17.10.2022)

ALLOY & TEMPER 6063-T6

DESCRIPTION --