

P-JAL-B-101

BEFORE APPROVAL CHECK ALL DIMENSIONS PROPERLY

D-7551

P-JAL-B-105

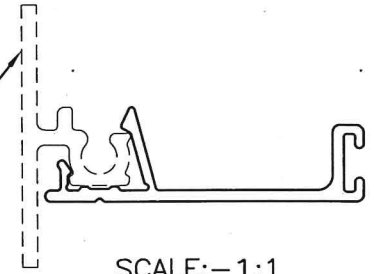

SCALE:- 1:1

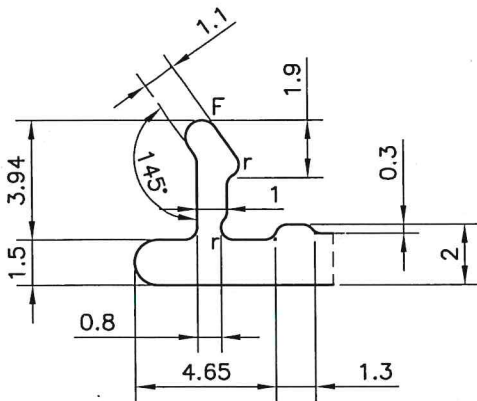
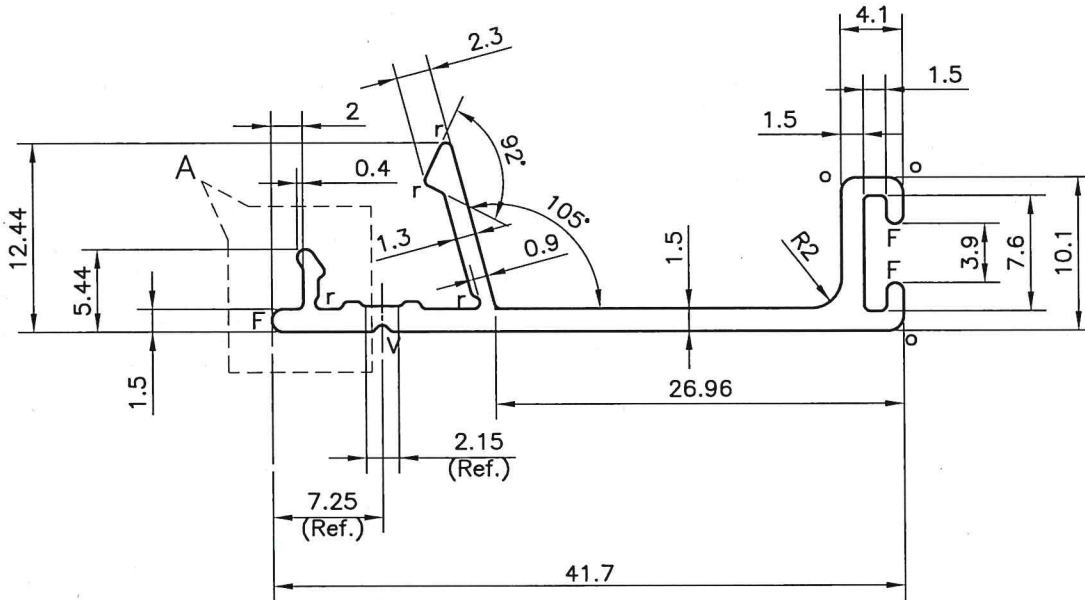

DETAIL A
SCALE 4:1

NOTE:-

$r = 0.40R$

F = FULL RADIUS

$o = 1.00R$

$V = 0.45 \times 90^\circ$



SYMBOL OF QUALITY
AN ISO 9001 COMPANY

JINDAL ALUMINIUM LTD.
BHIWADI-301019 (INDIA)

	NAME	DATE
DRAWN	AMIT	30-12-2022
CHECKED	<i>[Signature]</i>	20-1-23
APPROVED	<i>[Signature]</i>	20/01/23
SCALE	1:1,2:1&4:1	
AREA mm ²	103.01	
PERIMETER mm.	143.34	
WEIGHT kg/m	0.278	
DRAWING No.	SECTION No.	
P-JAL-B-101	D-7551	
-	-	
-	-	
-	-	

1. ALL DIMENSIONS ARE IN mm.
2. ROUND OFF ALL SHARP CORNERS WITH 0.40 mm.
3. TOLERANCES WILL BE AS PER BS:EN-755-9 , UNLESS OTHERWISE SPECIFIED

PARTY'S NAME	M/s. INTEGRITY WINDOWS & DOORS PVT. LTD.
PARTY'S DRAWING No.	AS PER DRAWING 137.952 (Q00306)
ALLOY & TEMPER	6063-T6
DESCRIPTION	--