

P-JAL-B-112

BEFORE APPROVAL CHECK ALL DIMENSIONS PROPERLY

D-7557

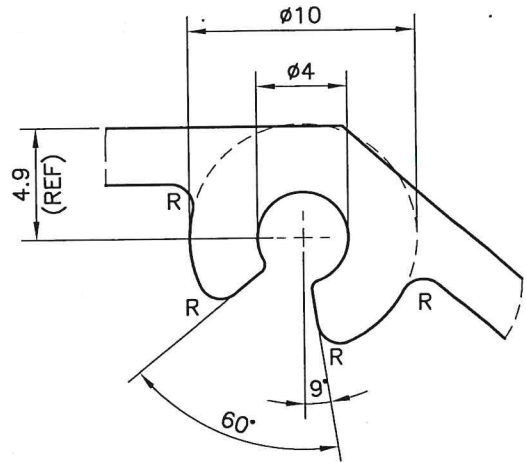

DETAIL A
SCALE 3:1

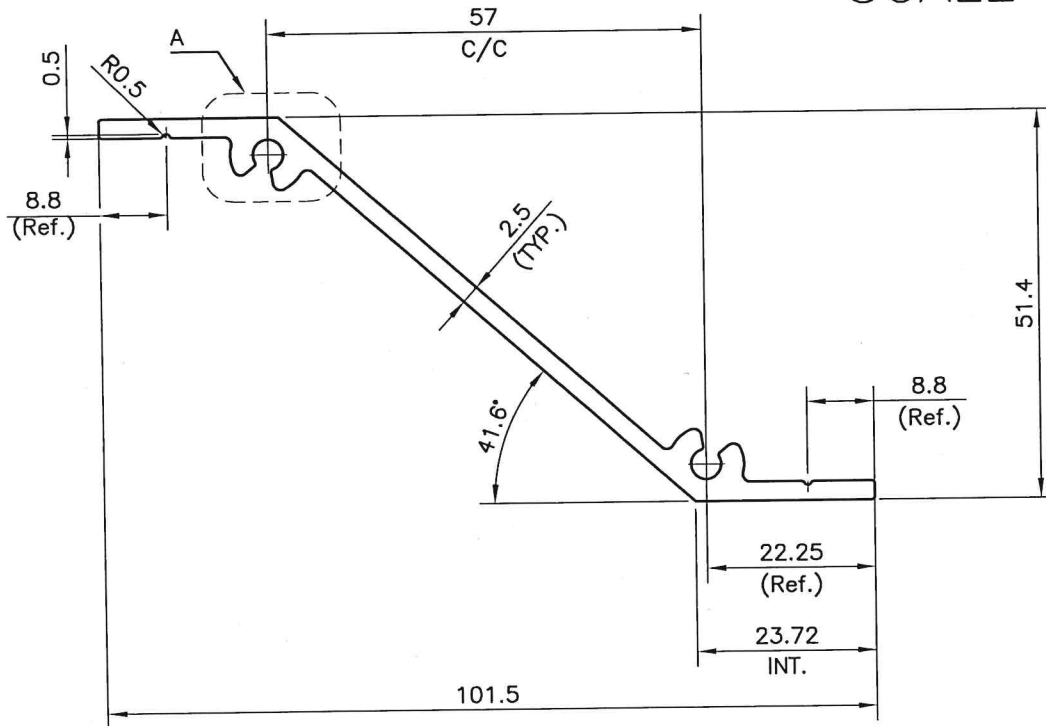

NOTE:
R=1.00R



SYMBOL OF QUALITY
AN ISO 9001 COMPANY

JINDAL ALUMINIUM LTD.
BHIWADI-301019 (INDIA)

| | NAME | DATE |
|-------------|-----------------|------------|
| DRAWN | ASHUTOSH | 20-01-2023 |
| CHECKED | <i>Jindal</i> | 6-2-23 |
| APPROVED | <i>Jindal</i> | 06/02/23 |
| SCALE | | 1:1&3:1 |
| AREA | mm ² | 360.12 |
| PERIMETER | mm. | 273.50 |
| WEIGHT | kg/m | 0.972 |
| DRAWING No. | SECTION No. | |
| P-JAL-B-112 | D-7557 | |
| | | |
| | | |

1. ALL DIMENSIONS ARE IN mm.
2. ROUND OFF ALL SHARP CORNERS WITH 0.40 mm.
3. TOLERANCES WILL BE AS PER BS:EN-755-9 , UNLESS OTHERWISE SPECIFIED

PARTY'S NAME M/s. ALUMINIUM TRADING CO.

PARTY'S DRAWING No. AS PER DRAWING (21472)

ALLOY & TEMPER HE9 WP

DESCRIPTION LOUVER SECTION