

P-JAL-B-113

BEFORE APPROVAL CHECK ALL DIMENSIONS PROPERLY

-

D-7558



SCALE 1:1

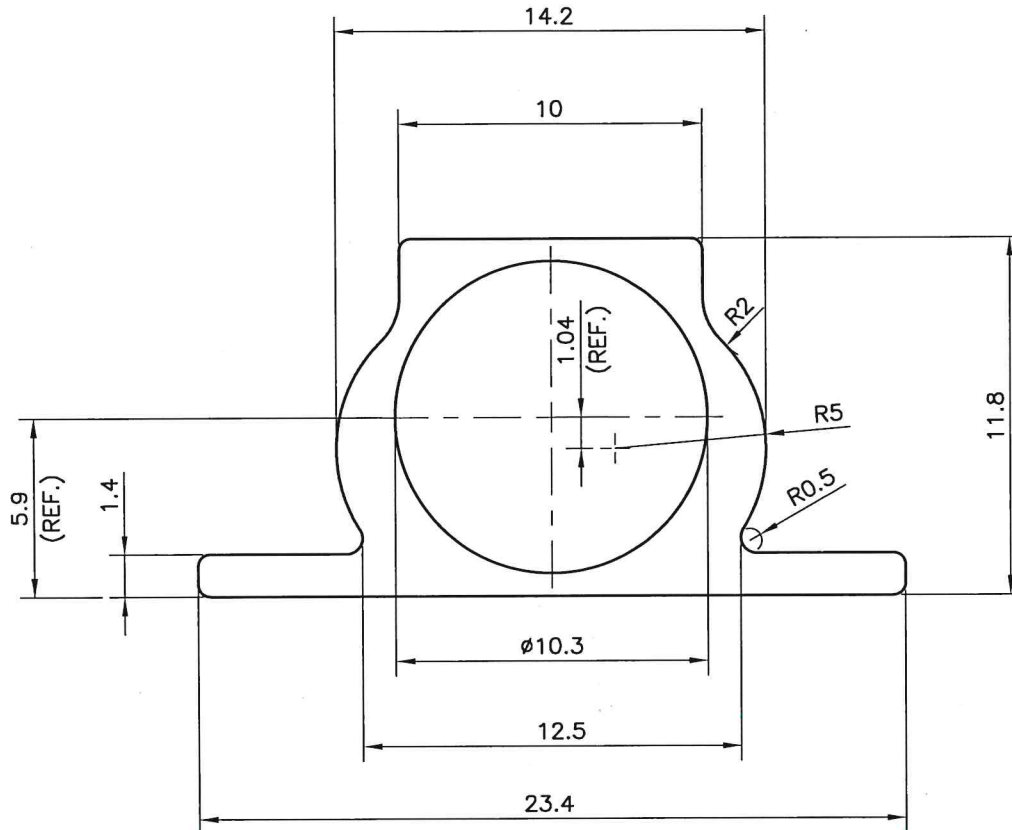

SYMBOL OF QUALITY  
AN ISO 9001 COMPANY

**JINDAL ALUMINIUM LTD.**

BHIWADI-301019 (INDIA)

	NAME	DATE
DRAWN	ASHUTOSH	30-01-2023
CHECKED	<i>Pratik</i>	9-2-23
APPROVED	<i>Pratik</i>	09-02-23
SCALE		1:1&4:1
AREA	mm <sup>2</sup>	77.42
PERIMETER	mm.	67.89
WEIGHT	kg/m	0.209
DRAWING No.	SECTION No.	
P-JAL-B-113	D-7558	

1. ALL DIMENSIONS ARE IN mm.
2. ROUND OFF ALL SHARP CORNERS WITH 0.40 mm.
3. TOLERANCES WILL BE AS PER BS:EN-755-9 , UNLESS OTHERWISE SPECIFIED

PARTY'S NAME	M/s. IMPERIAL METAL MART.
PARTY'S DRAWING No.	AS PER SAMPLE-1 (Q00381)
ALLOY & TEMPER	HE9 WP
DESCRIPTION	TOWER BOLT SECTION