

P-JAL-B-114

BEFORE APPROVAL CHECK ALL DIMENSIONS PROPERLY

D-7559

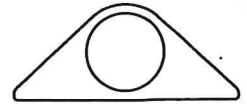

SCALE 1:1

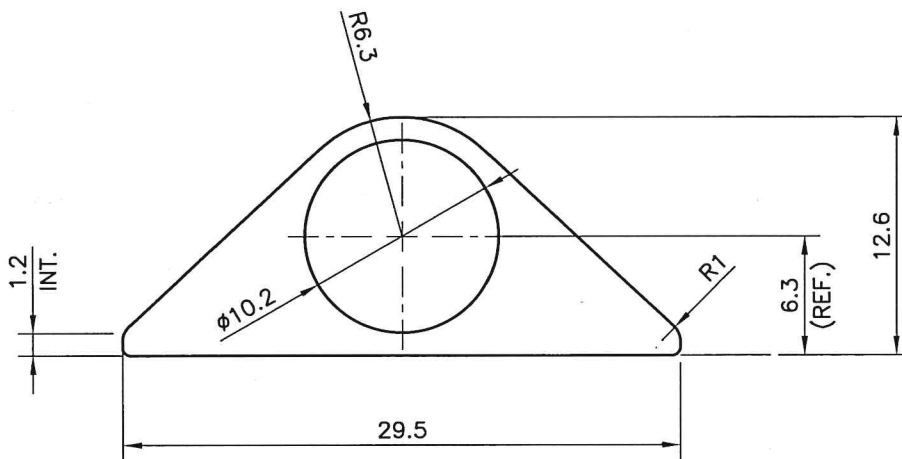

SYMBOL OF QUALITY  
AN ISO 9001 COMPANY

**JINDAL ALUMINIUM LTD.**  
BHIWADI-301019 (INDIA)

	NAME	DATE
DRAWN	ASHUTOSH	30-01-2023
CHECKED	<i>Amil</i>	9-2-23
APPROVED	<i>J.Roh</i>	09.02.23

1. ALL DIMENSIONS ARE IN mm.
2. ROUND OFF ALL SHARP CORNERS WITH 0.40 mm.
3. TOLERANCES WILL BE AS PER BS:EN-755-9 , UNLESS OTHERWISE SPECIFIED

SCALE	1:1&2.5:1
AREA mm <sup>2</sup>	148.45
PERIMETER mm.	69.44
WEIGHT kg/m	0.401

PARTY'S NAME	M/s. IMPERIAL METAL MART.	DRAWING No.	SECTION No.
PARTY'S DRAWING No.	AS PER DRAWING LIGHTER THEN 18105 (Q00382)	P-JAL-B-114	D-7559
ALLOY & TEMPER	HE9 WP A3D		
DESCRIPTION	TOWER BOLT SECTION		