

P-JAL-B-150

BEFORE APPROVAL CHECK ALL DIMENSIONS PROPERLY

D-7582

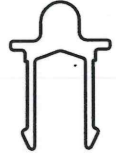

SCALE 1:1

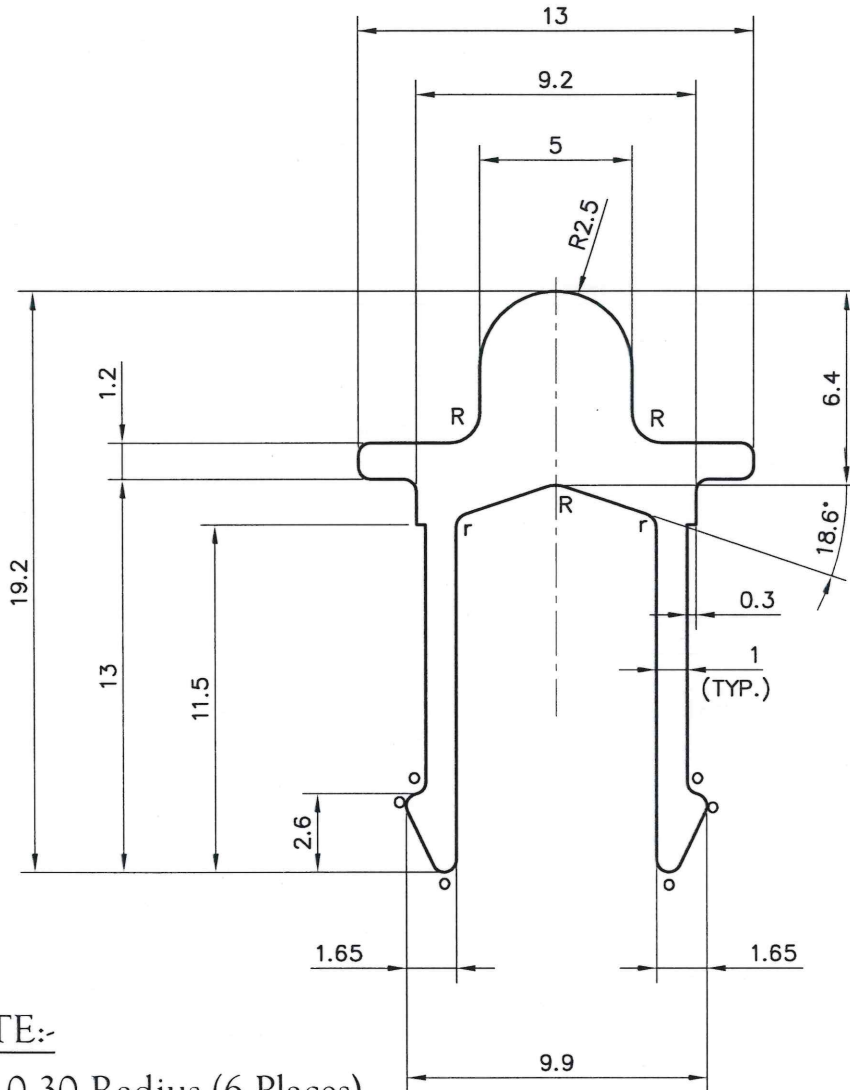

NOTE:-

o = 0.30 Radius (6 Places)

r = 0.50 Radius (2 Places)

R = 1.0 Radius (3 Places)

SYMBOL OF QUALITY
AN ISO 9001 COMPANY

JINDAL ALUMINIUM LTD.
BHIWADI-301019 (INDIA)

1. ALL DIMENSIONS ARE IN mm.
2. ROUND OFF ALL SHARP CORNERS WITH 0.40 mm.
3. TOLERANCES WILL BE AS PER BS:EN-755-9, UNLESS OTHERWISE SPECIFIED

PARTY'S NAME M/s. SHANKAR FENESTRATIONS & GLASSES (I) PVT. LTD.

PARTY'S DRAWING No. AS PER DRAWING-GUIDE RAIL (Q00466)

ALLOY & TEMPER 6063-T6

DESCRIPTION WINDOW SECTION

	NAME	DATE
DRAWN	AMIT	29-03-2023
CHECKED	<i>Jindal</i>	24.4.23
APPROVED	<i>Pran</i>	24.4.23
SCALE		1:1&4:1
AREA mm ²		71.0317
PERIMETER mm.		83.95
WEIGHT kg/m		0.192
DRAWING No.		SECTION No.
P-JAL-B-150		D-7582
-		-