

SCALE 1:1

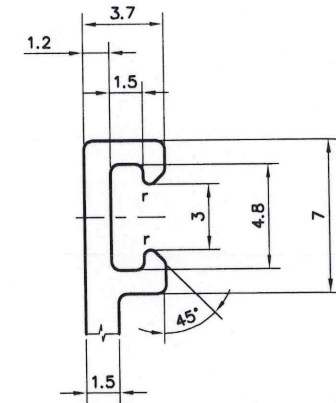

DETAIL A  
SCALE 4:1

NOTE:-

$r = 0.40$  Radius (4 Places)

$V = 0.70$  Radius X 0.30 Depth (4 Places)

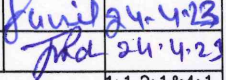
 SYMBOL OF QUALITY AN ISO 9001 COMPANY	<b>JINDAL ALUMINIUM LTD.</b> BHIWADI-301019 (INDIA)		NAME	DATE
			DRAWN	ASHUTOSH 04-04-2023
1. ALL DIMENSIONS ARE IN mm. 2. ROUND OFF ALL SHARP CORNERS WITH 0.40 mm. 3. TOLERANCES WILL BE AS PER BS:EN-755-9, UNLESS OTHERWISE SPECIFIED	PARTY'S NAME		M/s. SHANKAR FENESTRATIONS & GLASSES (I) PVT. LTD.	
	PARTY'S DRAWING No.		AS PER DRAWING-OUTER FRAME (Q00469)	
	ALLOY & TEMPER		6063-T6	
DESCRIPTION		WINDOW SECTION		
		APPROVED		 24.4.23
		SCALE		1:1, 2:1 & 4:1
		AREA mm <sup>2</sup>		274.10
		PERIMETER mm.		250.72
		WEIGHT kg/m		0.740
		DRAWING No.		P-JAL-B-153
		SECTION No.		D-7585