

P-JAL-B-157

BEFORE APPROVAL CHECK ALL DIMENSIONS PROPERLY

D-7589

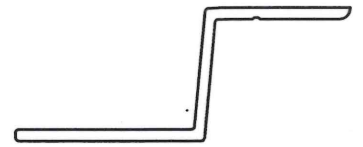

SCALE 1:1

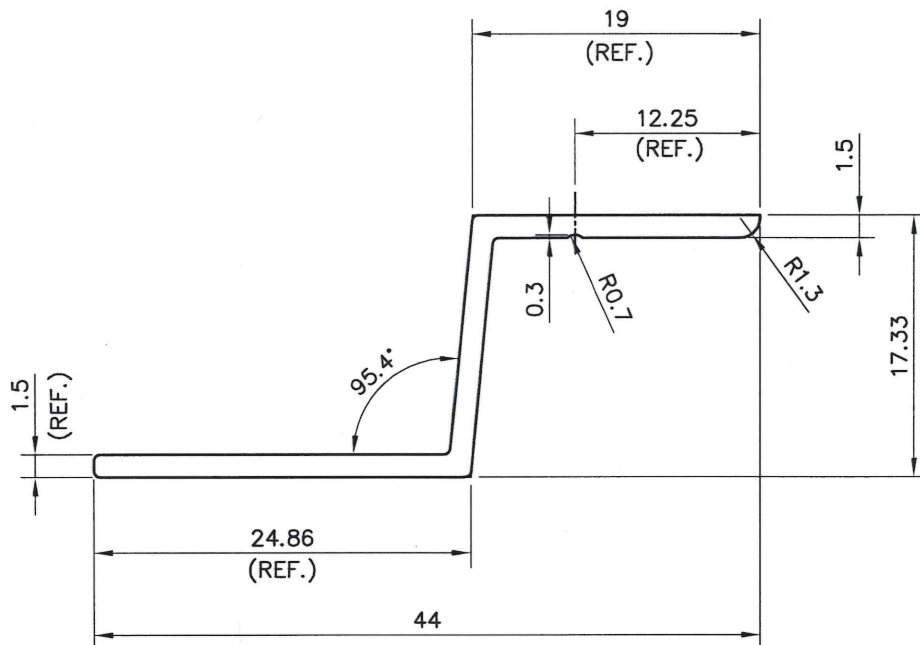

SYMBOL OF QUALITY  
AN ISO 9001 COMPANY

**JINDAL ALUMINIUM LTD.**  
BHIWADI-301019 (INDIA)

1. ALL DIMENSIONS ARE IN mm.
2. ROUND OFF ALL SHARP CORNERS WITH 0.40 mm.
3. TOLERANCES WILL BE AS PER BS:EN-755-9 , UNLESS OTHERWISE SPECIFIED

PARTY'S NAME	M/s. SHANKAR FENESTRATIONS & GLASSES (I) PVT. LTD.
PARTY'S DRAWING No.	AS PER DRAWING-FLOOR FLUSH CLIP (Q00473)
ALLOY & TEMPER	6063-T6
DESCRIPTION	WINDOW SECTION

	NAME	DATE
DRAWN	ASHUTOSH	04-04-2023
CHECKED	Juni	24.4.23
APPROVED	Pran	24.4.23
SCALE	1:1 & 2:1	
AREA mm <sup>2</sup>	87.03	
PERIMETER mm.	118.446	
WEIGHT kg/m	0.235	
DRAWING No.	SECTION No.	
P-JAL-B-157	D-7589	
-	-	