

P-JAL-B-159

BEFORE APPROVAL CHECK ALL DIMENSIONS PROPERLY

D-7591

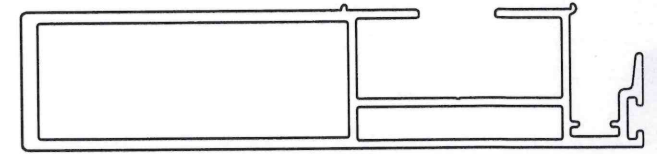

SCALE 1:1

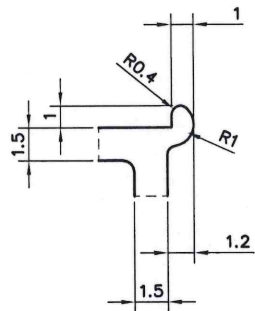
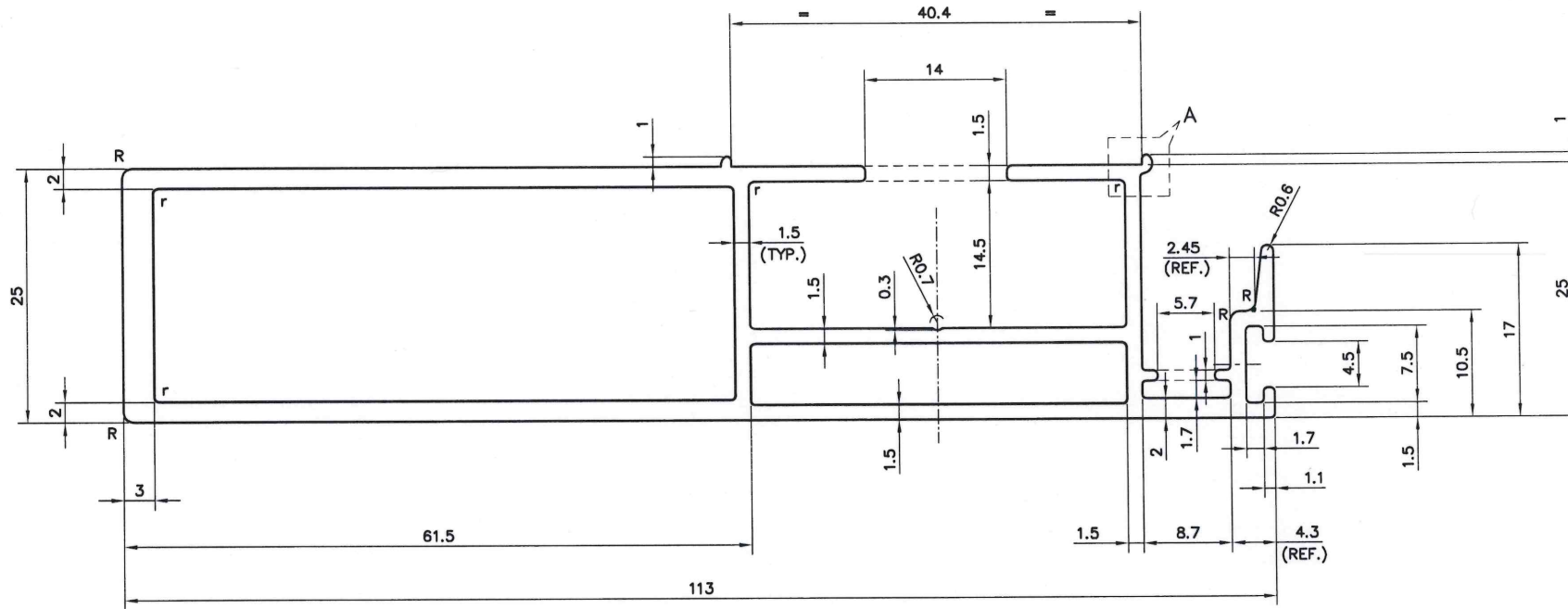

DETAIL A
SCALE 4:1

NOTE:-

R = 0.5 Radius (2 Place)

F= Full Radius (2 Places)

NOTE:-

R = R1.0

r = R0.50

<p>SYMBOL OF QUALITY AN ISO 9001 COMPANY</p>	<p>JINDAL ALUMINIUM LTD. BHIWADI-301019 (INDIA)</p>	NAME	DATE
		DRAWN	ASHUTOSH 04-04-2023
		CHECKED	June 24.4.23
		APPROVED	Man 24.4.23
<p>1. ALL DIMENSIONS ARE IN mm. 2. ROUND OFF ALL SHARP CORNERS WITH 0.40 mm. 3. TOLERANCES WILL BE AS PER BS:EN-755-9 , UNLESS OTHERWISE SPECIFIED</p>		SCALE	1:1,2:1&4:1
PARTY'S NAME		M/s. SHANKAR FENESTRATIONS & GLASSES (I) PVT. LTD.	AREA mm ²
PARTY'S DRAWING No.		AS PER DRAWING-INTERLOCK FRAME (Q00475)	PERIMETER mm.
ALLOY & TEMPER		6063-T6	WEIGHT kg/m
DESCRIPTION		WINDOW SECTION	
		DRAWING No.	SECTION No.
		P-JAL-B-159	D-7591