

P-JAL-B-142-2

BEFORE APPROVAL CHECK ALL DIMENSIONS PROPERLY

D-7596

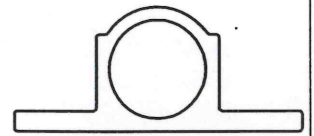

SCALE 1:1

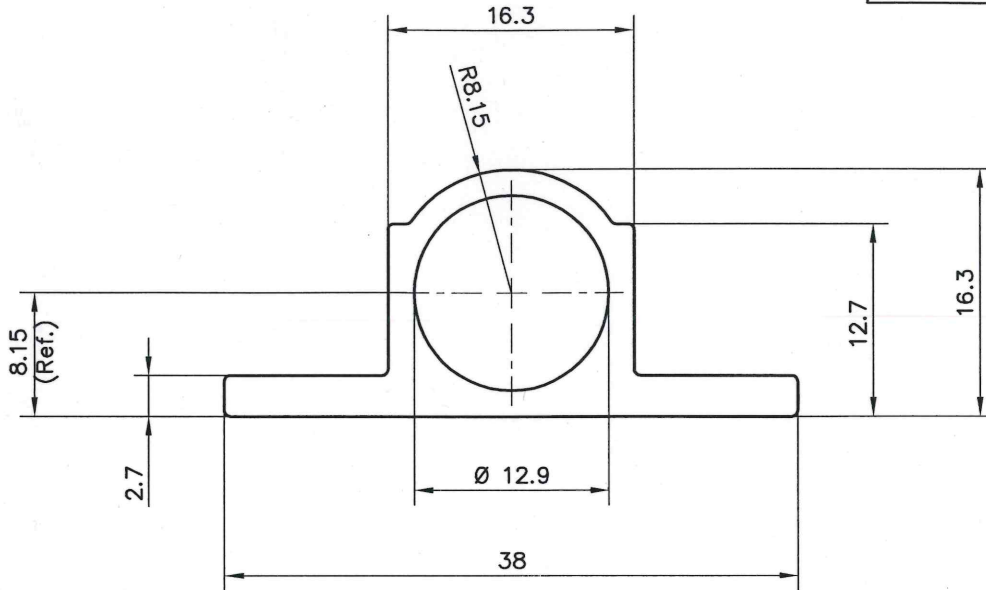

WEIGHT RANGE : 1.610KG/12' TO 1.720 KG/12'

- 1. STRAIGHTNESS= 1.7mm/M
- 2. TWIST= 1.7mm/M
- 3. ANGULARITY= ±2°
- 4. FLATNESS= 0.007xWIDTH

1) THE WELDING LINE IN THE EXPOSED SURFACE OF PROFILE IS UNAVOIDABLE. 2) PLEASE SPECIFY IMPORTANT SIZES. 3) PLEASE SPECIFY IF THIS PROFILE MATCHES WITH OTHER PROFILES. 4) PLEASE SPECIFY EXPOSED SURFACE. OTHERWISE CONSIDERED AS NO EXPOSED SURFACE. 5) FINISH :- MILL FINISH / ANODIZING / POWDER COATING

 SYMBOL OF QUALITY AN ISO 9001 COMPANY	JINDAL ALUMINIUM LTD. BHIWADI-301019 (INDIA)	NAME	DATE
		DRAWN ASHUTOSH	21-03-2023
		CHECKED <i>[Signature]</i>	11-5-23
		APPROVED <i>[Signature]</i>	11/05/23
1. ALL DIMENSIONS ARE IN mm. 2. ROUND OFF ALL SHARP CORNERS WITH 0.40 mm. 3. TOLERANCES WILL BE AS PER BS:EN-755-9 , UNLESS OTHERWISE SPECIFIED		SCALE	1:1&2:1
		AREA mm ²	169.01
		PERIMETER mm.	102.39
PARTY'S NAME	M/s. IMPERIAL METALMART-DELHI	WEIGHT kg/m	0.456
PARTY'S DRAWING No.	AS PER MAIL -21.03.2023	DRAWING No.	SECTION No.
ALLOY & TEMPER	HE9 WP	P-JAL-B-142-2	D-7596
DESCRIPTION	TOWER BOLT		