

P-JAL-B-199

D7597

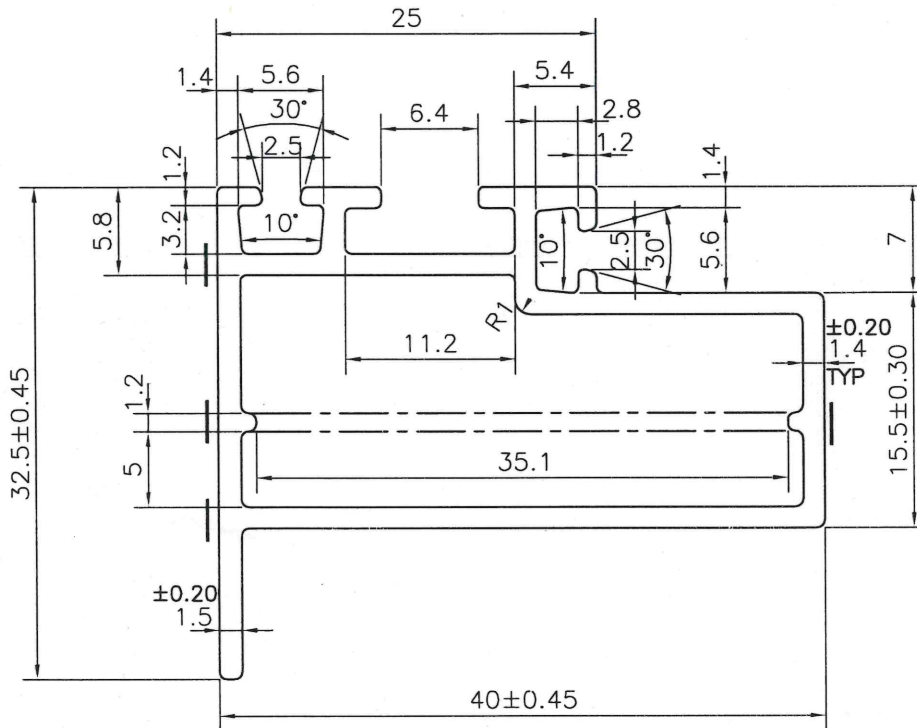
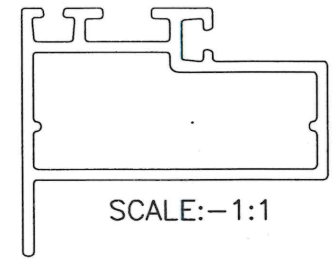

PLEASE NOTE:-  
 — DUE TO THICKNESS VARIATION IMPRESSION MARK MAY APPEAR IN THIS MARKED PORTION.

1. STRAIGHTNESS=1.7mm/M
2. TWIST=1.7mm/M
3. ANGULARITY= ±2°
4. FLATNESS =0.007xWIDTH



**JINDAL ALUMINIUM LTD.**  
 BHIWADI-301019 (INDIA)

	NAME	DATE
DRAWN	ASHUTOSH	12-05-2023
CHECKED	<i>[Signature]</i>	12-05-23
APPROVED	<i>[Signature]</i>	12/05/23

1. ALL DIMENSIONS ARE IN mm.  
 2. ROUND OFF ALL SHARP CORNERS WITH 0.40 mm.  
 3. TOLERANCES WILL BE AS PER IS:6477-1983, UNLESS OTHERWISE SPECIFIED

SCALE	2:1
AREA mm <sup>2</sup>	213.043
PERIMETER mm.	185.583
WEIGHT kg/m	0.575

PARTY'S NAME	ALUMINIUM TRADING CO., DELHI
PARTY'S DRAWING No.	AS PER DRAWING
ALLOY & TEMPER	6063 T6
DESCRIPTION	SUBFRAME-CURTAIN WALL SECTION

DRAWING No.	SECTION No.
P-JAL-B-199	-
D7597	D7597