

P-JAL-B-252

D7602

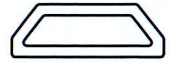

SCALE 1:1

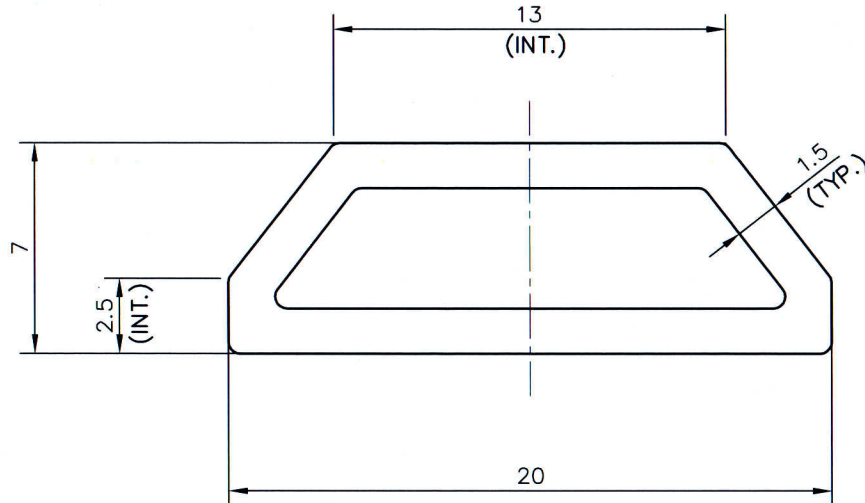

1. STRAIGHTNESS= 1.7mm/M
2. TWIST= 1.7mm/M
3. ANGULARITY= $\pm 2^\circ$
4. FLATNESS= 0.007xWIDTH

(Q00735)

 SYMBOL OF QUALITY AN ISO 9001 COMPANY	JINDAL ALUMINIUM LTD. BHIWADI-301019 (INDIA)	NAME	DATE
		DRAWN	ASHUTOSH
1. ALL DIMENSIONS ARE IN mm. 2. ROUND OFF ALL SHARP CORNERS WITH 0.40 mm. 3. TOLERANCES WILL BE AS PER BS:EN-755-9 , UNLESS OTHERWISE SPECIFIED		CHECKED	<i>Junal</i> 11/7/23
		APPROVED	<i>Jha</i> 11/07/23
PARTY'S NAME M/s. TUTEJA WINDOW SOLUTION		SCALE	4:1
		AREA mm ²	65.90
PARTY'S DRAWING No. AS PER SAMPLE		PERIMETER mm.	48.98
		WEIGHT kg/m	0.178
ALLOY & TEMPER 6063-T6		DRAWING No.	SECTION No.
		P-JAL-B-252	
DESCRIPTION MISC. TUBE		D7602	D7602