

-
D877

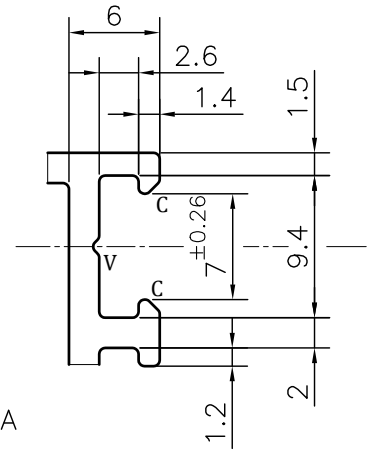

DETAIL A
SCALE 2:1

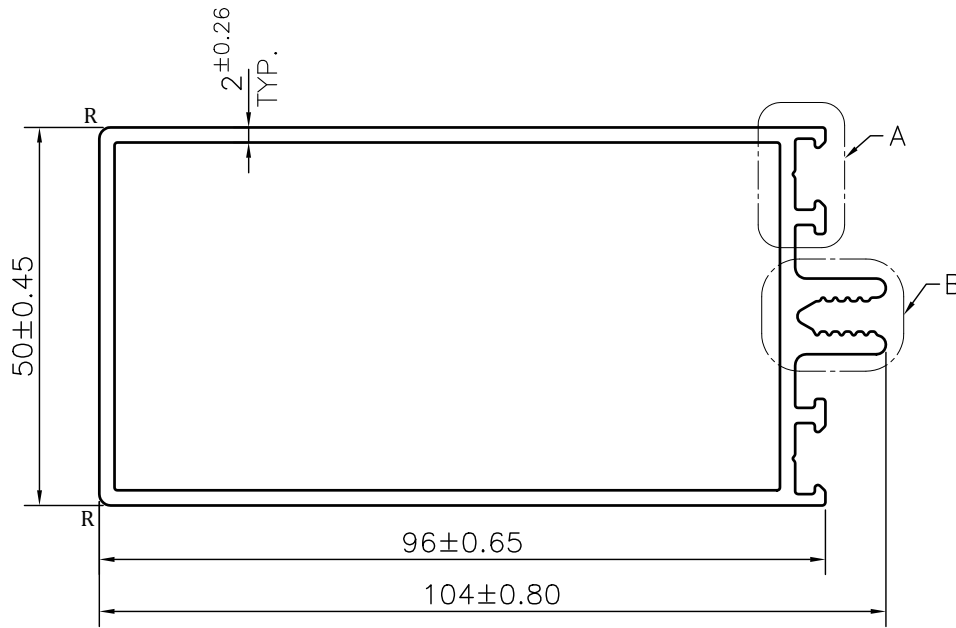
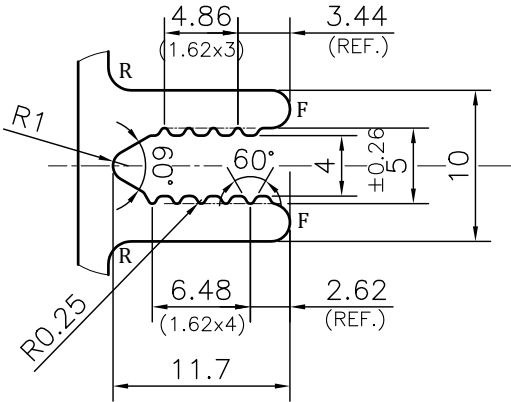

DETAIL B
SCALE 2:1

NOTE:-

- R= 1.50 RADIUS (4 PLACES)**
- F= FULL RADIUS (2 PLACES)**
- C= 0.8x45° CHAMFER (4 PLACES)**
- V= 0.3x90° V-GROOVE (2 PLACES)**

1. STRAIGHTNESS= 1.7mm/M
2. TWIST= 1.7mm/M
3. ANGULARITY= ±2°
4. FLATNESS= 0.007xWIDTH

 SYMBOL OF QUALITY AN ISO 9001 COMPANY	JINDAL ALUMINIUM LTD. BHIWADI-301019 (INDIA)		NAME	DATE
			DRAWN	ASHUTOSH
1. ALL DIMENSIONS ARE IN mm. 2. ROUND OFF ALL SHARP CORNERS WITH 0.40 mm. 3. TOLERANCES WILL BE AS PER BS:EN-755-9 , UNLESS OTHERWISE SPECIFIED			CHECKED	
			APPROVED	
PARTY'S NAME WINDOW CRAFT			SCALE	1:1
			AREA mm ²	659.691
PARTY'S DRAWING No. AS PER DRAWING			PERIMETER mm.	368.845
			WEIGHT kg/m	1.781
ALLOY & TEMPER 6063 T5			DRAWING No.	SECTION No.
			-	-
DESCRIPTION CURTAIN WALL SECTION			D877	D877
PRODUCT CODE:-055 HSN CODE:- 76042100				