

IAL-D-970

D970

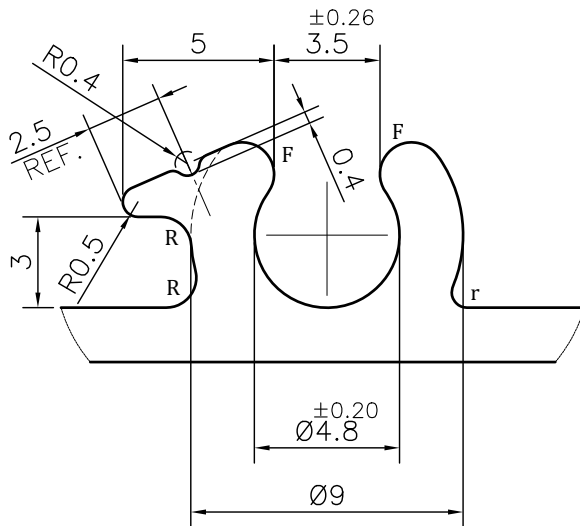
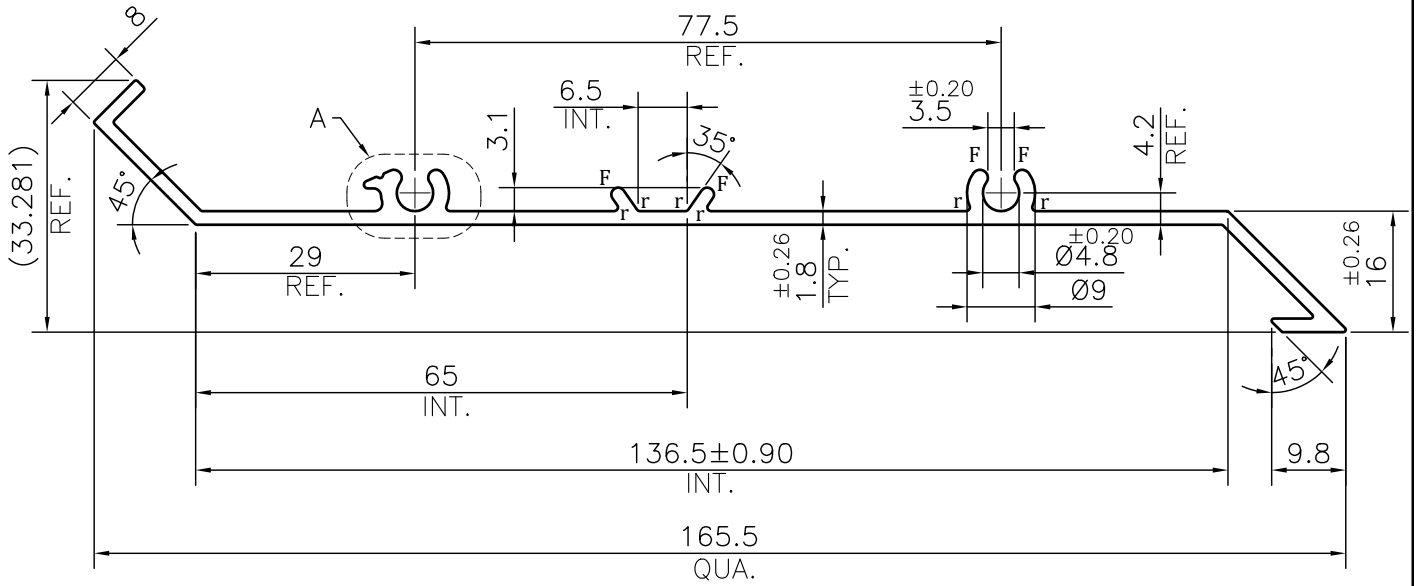

DETAIL A
SCALE 4:1

NOTE:-

- r= 0.50 RADIUS (7 PLACES)**
- R= 1.0 RADIUS (2 PLACES)**
- F= FULL RADIUS (6 PLACES)**

ROUND OFF ALL SHARP CORNERS WITH 0.30 mm.

1. STRAIGHTNESS= 1.7mm/M
2. TWIST= 1.7mm/M
3. ANGULARITY= ±2°
4. FLATNESS= 0.007xWIDTH



SYMBOL OF QUALITY
AN ISO 9001 COMPANY

JINDAL ALUMINIUM LTD.
BHIWADI-301019 (INDIA)

	NAME	DATE
DRAWN	ASHUTOSH	28-09-2023
CHECKED		
APPROVED		
SCALE		1:1
AREA mm ²		404.021
PERIMETER mm.		429.75
WEIGHT kg/m		1.091
DRAWING No.	SECTION No.	
IAL-D-970	-	
D970	D970	

1. ALL DIMENSIONS ARE IN mm.
2. ROUND OFF ALL SHARP CORNERS WITH 0.40 mm.
3. TOLERANCES WILL BE AS PER BS:EN-755-9 , UNLESS OTHERWISE SPECIFIED

PARTY'S NAME	CARYAIRE	
PARTY'S DRAWING No.	AS PER DRAWING	
ALLOY & TEMPER	HE9 WP	PRODUCT CODE:-082
		HSN CODE:- 76042990
DESCRIPTION	AIR GRILL SECTION	