

P-10791-1

E0002

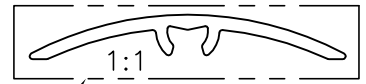

EXPOSED SURFACE

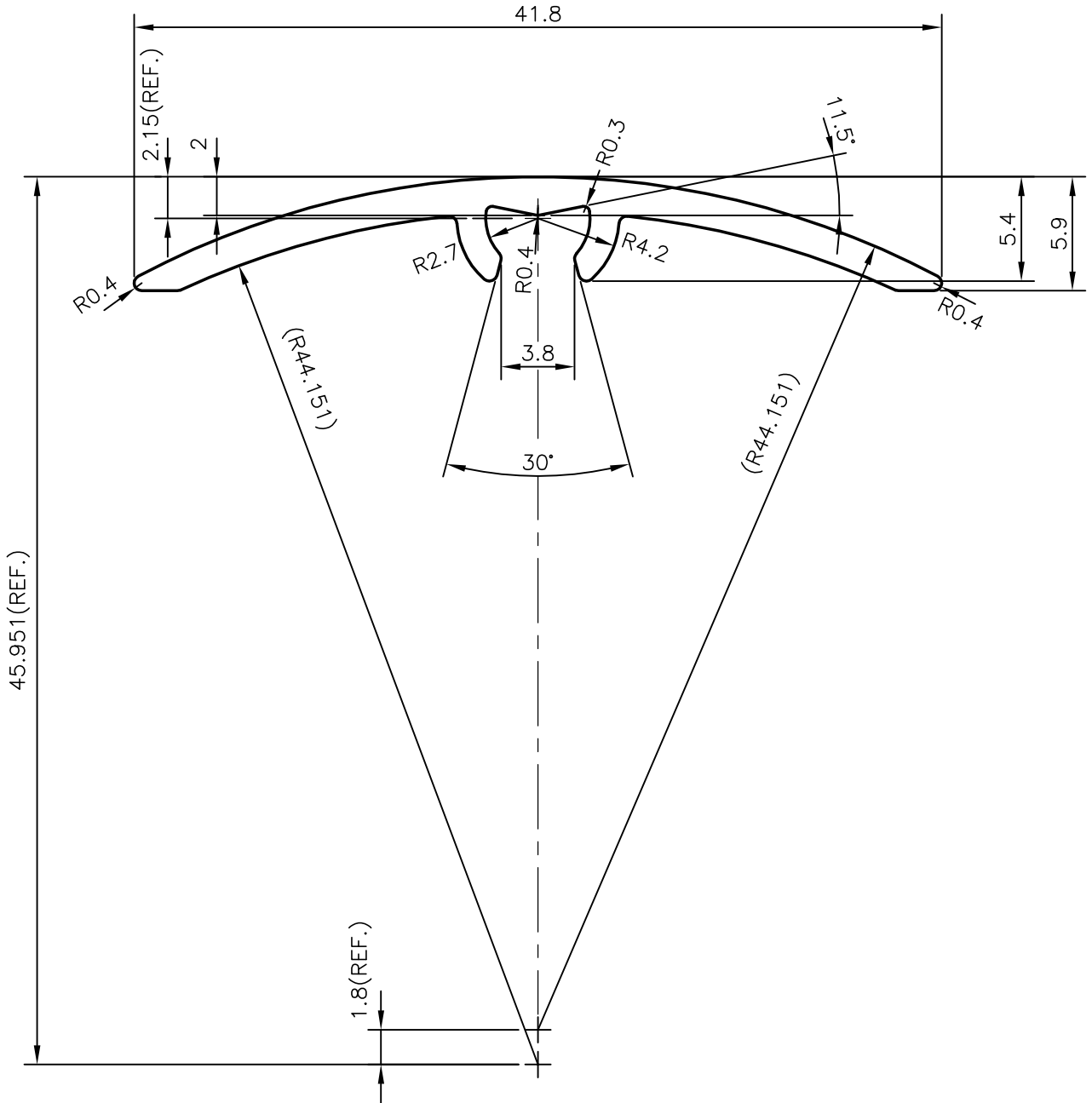

45.951(REF.)

41.8

2.15(REF.)

2

11.5

5.4

5.9

R0.4

R2.7

R0.4

R0.3

R4.2

R0.4

(R44.151)

(R44.151)

3.8

30°

1.8(REF.)



SYMBOL OF QUALITY  
AN ISO 9001 COMPANY

**JINDAL ALUMINIUM LTD.**  
BANGALORE-560073 (INDIA)

	NAME	DATE
DRAWN	J.P.KAUSHIK	23-02-2011
CHECKED		
APPROVED	S.S.GARG	28-02-2011
SCALE		3:1
AREA mm <sup>2</sup>		82.224
PERIMETER mm.		100.409
WEIGHT kg/m		0.222
DRAWING No.	SECTION No.	
P-10791-1	-	
E0002	E0002	

1. ALL DIMENSIONS ARE IN mm.
2. ROUND OFF ALL SHARP CORNERS WITH 0.40 mm.
3. TOLERANCES WILL BE AS PER IS:3965-1981 UNLESS OTHERWISE SPECIFIED

PARTY'S NAME	SURFACES., BANGALORE
PARTY'S DRAWING No.	AS PER REQUIREMENT
ALLOY & TEMPER	HE9 WP
DESCRIPTION	FURNITURE SECTION