

P-10889-1

E0007

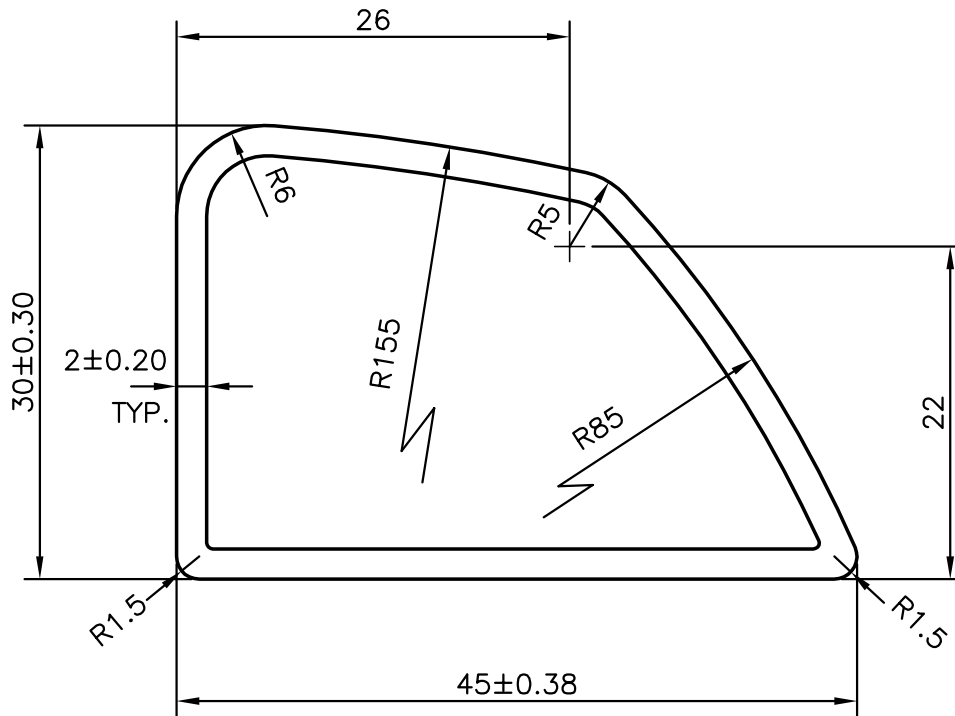
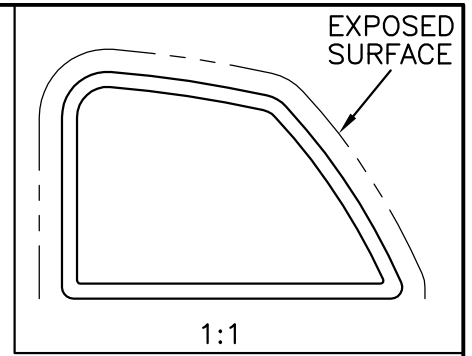

SYMBOL OF QUALITY
AN ISO 9001 COMPANY

JINDAL ALUMINIUM LTD.
BANGALORE-560073 (INDIA)

	NAME	DATE
DRAWN	R.D.Sharma	20-04-2011
CHECKED		
APPROVED	S.S.GARG	26-04-2011
SCALE		2:1
AREA mm ²		250.486
PERIMETER mm.		131.559
WEIGHT kg/m		0.676
DRAWING No.	SECTION No.	
P-10889-1	-	
E0007	E0007	

1. ALL DIMENSIONS ARE IN mm.
2. ROUND OFF ALL SHARP CORNERS WITH 0.40 mm.
3. TOLERANCES WILL BE AS PER IS:6477-1983 UNLESS OTHERWISE SPECIFIED

PARTY'S NAME	TEAM CONCEPTS PVT. LTD., BANGALORE
PARTY'S DRAWING No.	754
ALLOY & TEMPER	6063 T4
DESCRIPTION	MISC. TUBE