

P-10853-2

E0017

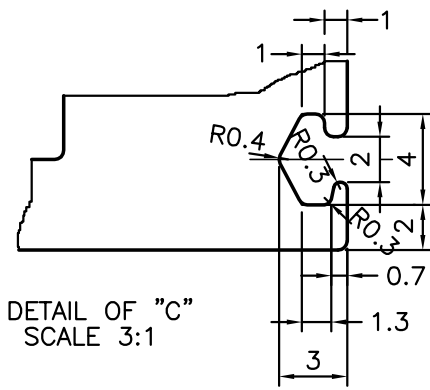

DETAIL OF "C"
SCALE 3:1

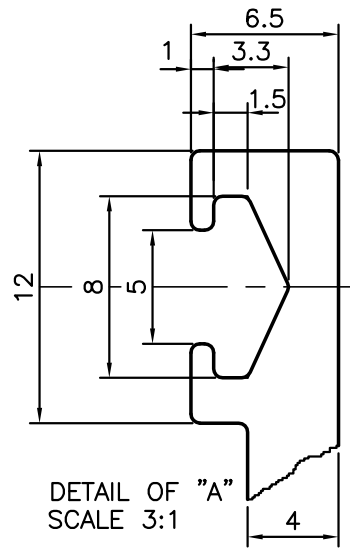

DETAIL OF "A"
SCALE 3:1

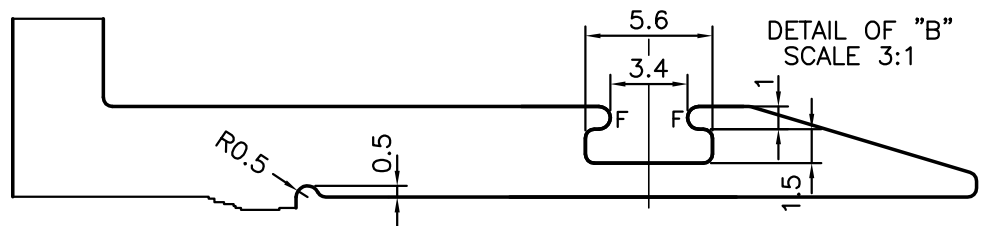
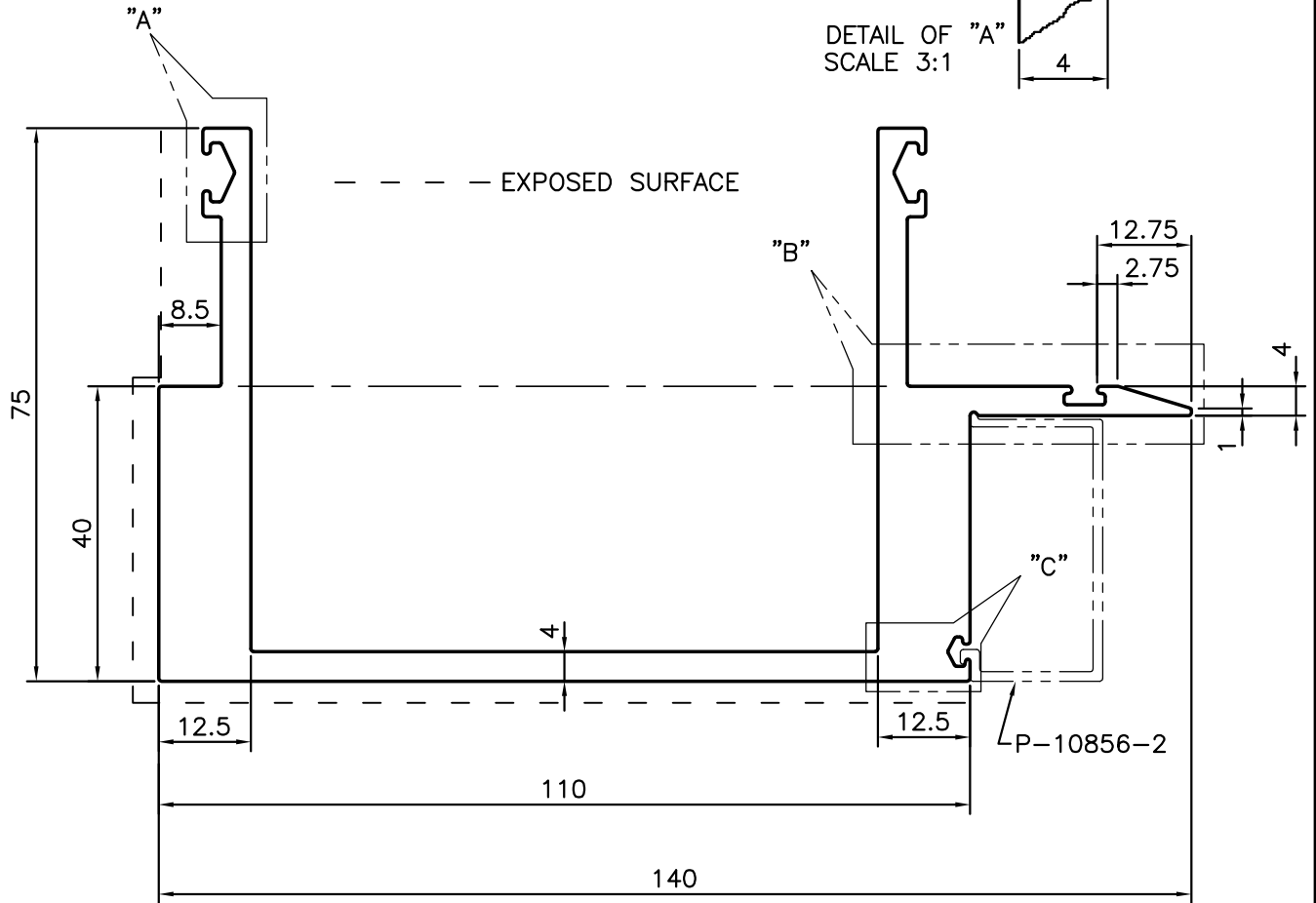

DETAIL OF "B"
SCALE 3:1



SYMBOL OF QUALITY
AN ISO 9001 COMPANY

JINDAL ALUMINIUM LTD.
BANGALORE-560073 (INDIA)

	NAME	DATE
DRAWN	J.P.KAUSHIK	11-06-2011
CHECKED		
APPROVED	S.S.GARG	08-07-2011
SCALE		1:1
AREA mm ²		1715.252
PERIMETER mm.		613.734
WEIGHT kg/m		4.631
DRAWING No.	SECTION No.	
P-10853-2	-	
E0017	E0017	

1. ALL DIMENSIONS ARE IN mm.
2. ROUND OFF ALL SHARP CORNERS WITH 0.40 mm.
3. TOLERANCES WILL BE AS PER IS:3965-1981 UNLESS OTHERWISE SPECIFIED

PARTY'S NAME	ALUPRO BUILDING SYSTEMS (P) LTD.,BANGALORE
PARTY'S DRAWING No.	AS PER DRAWING
ALLOY & TEMPER	HE9 WP
DESCRIPTION	CURTAIN WALL SECTION