

P-10854-2

E0018

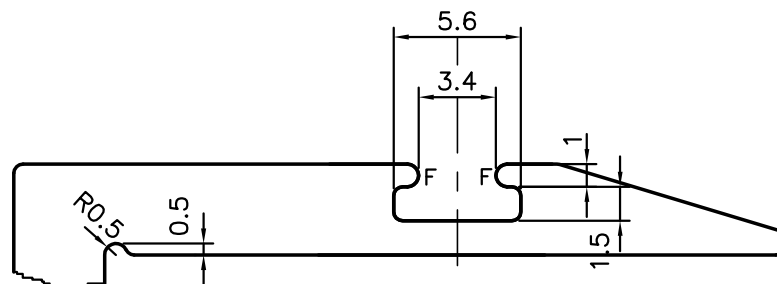

DETAIL OF "B"
SCALE 3:1

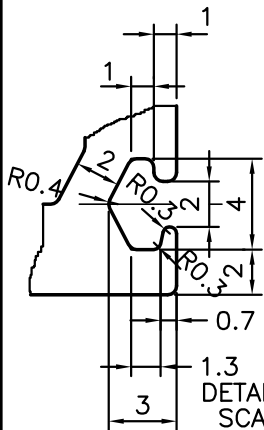
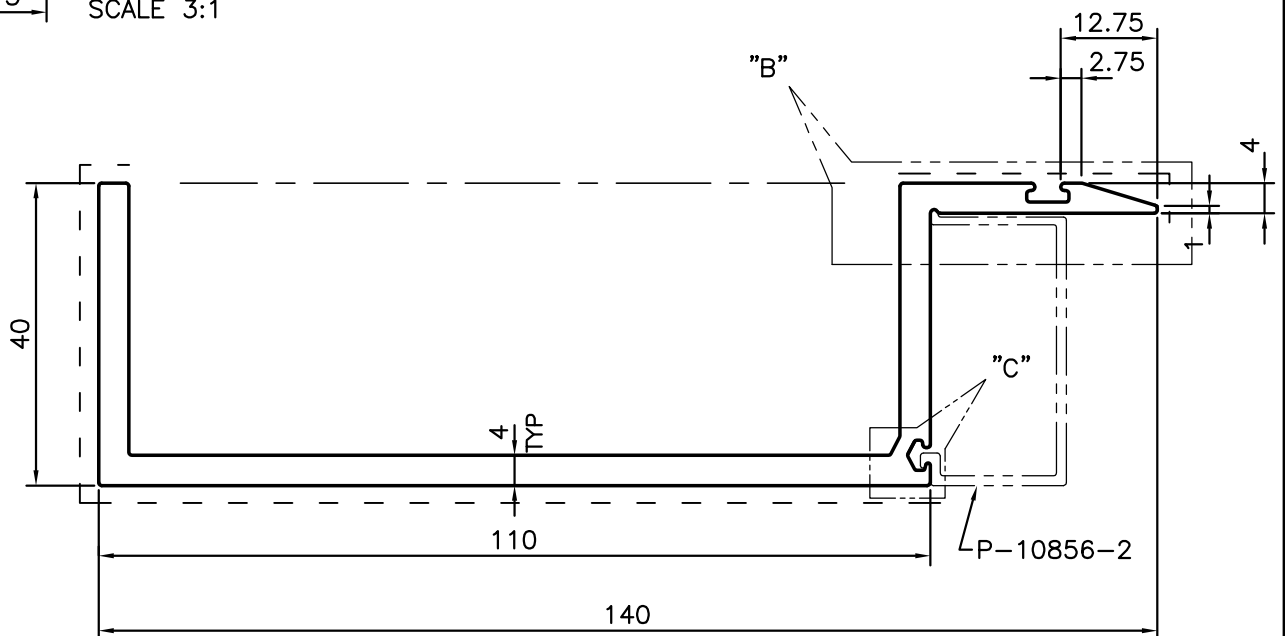

--- EXPOSED SURFACE



SYMBOL OF QUALITY
AN ISO 9001 COMPANY

JINDAL ALUMINIUM LTD.
BANGALORE-560073 (INDIA)

	NAME	DATE
DRAWN	J.P.KAUSHIK	11-06-2011
CHECKED		
APPROVED	S.S.GARG	08-07-2011

1. ALL DIMENSIONS ARE IN mm.
2. ROUND OFF ALL SHARP CORNERS WITH 0.40 mm.
3. TOLERANCES WILL BE AS PER IS:3965-1981 UNLESS OTHERWISE SPECIFIED

SCALE	1:1
AREA mm ²	813.691
PERIMETER mm.	442.846
WEIGHT kg/m	2.197

PARTY'S NAME	ALUPRO BUILDING SYSTEMS (P) LTD.,BANGALORE
PARTY'S DRAWING No.	AS PER DRAWING
ALLOY & TEMPER	HE9 WP
DESCRIPTION	CURTAIN WALL SECTION

DRAWING No.	SECTION No.
P-10854-2	-
E0018	E0018