

P-10862-2

E0026

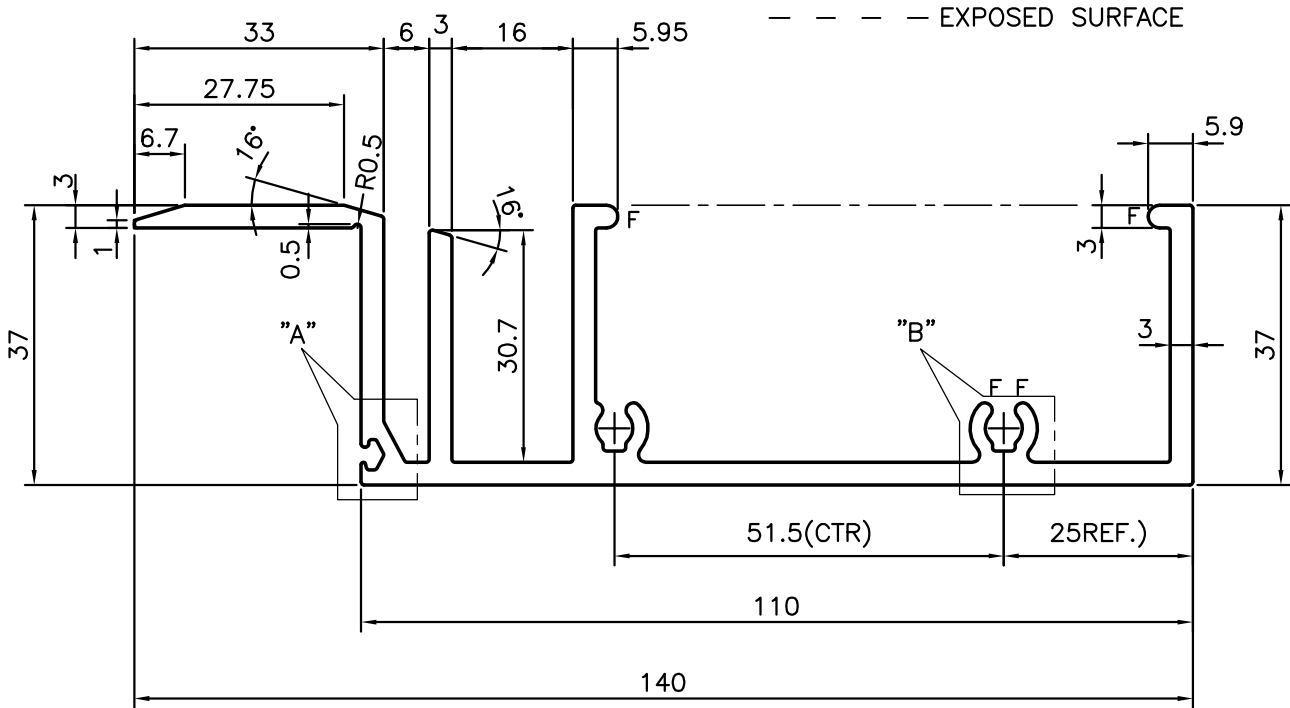

F = FULL RADIUS (5 PLACES)

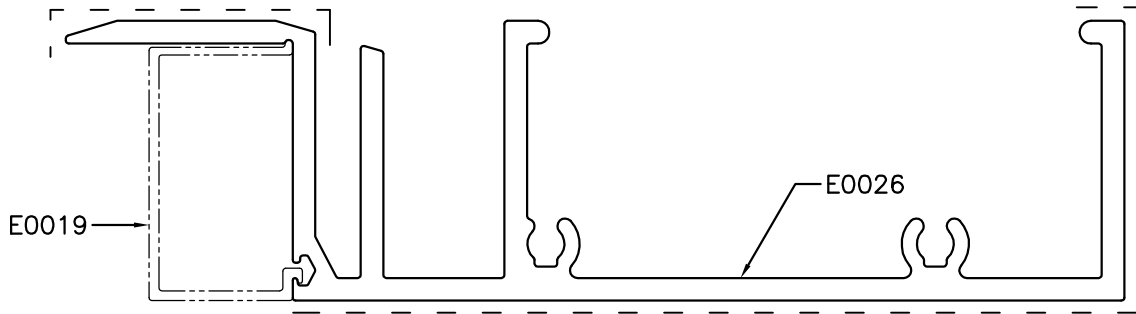
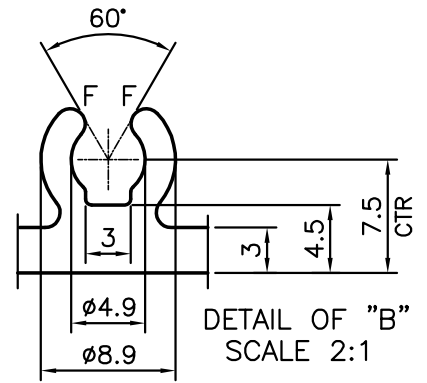
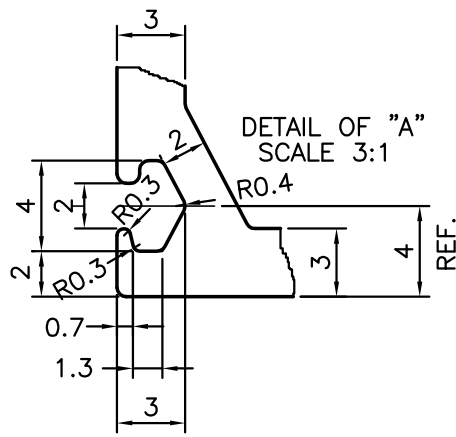

SYMBOL OF QUALITY
AN ISO 9001 COMPANY

JINDAL ALUMINIUM LTD.
BANGALORE-560073 (INDIA)

	NAME	DATE
DRAWN	RAGHAVENDRA	11-06-2011
CHECKED		
APPROVED	S.S.GARG	08-07-2011

1. ALL DIMENSIONS ARE IN mm.
2. ROUND OFF ALL SHARP CORNERS WITH 0.40 mm.
3. TOLERANCES WILL BE AS PER IS:3965-1981 UNLESS OTHERWISE SPECIFIED

SCALE	1:1
AREA mm ²	883.011
PERIMETER mm.	600.945
WEIGHT kg/m	2.384

PARTY'S NAME	ALUPRO BUILDING SYSTEMS (P) LTD.,BANGALORE
PARTY'S DRAWING No.	AS PER DRAWING
ALLOY & TEMPER	HE9 WP
DESCRIPTION	CURTAIN WALL SECTION

DRAWING No.	SECTION No.
P-10862-2	-
E0026	E0026