

P-10863

E0027

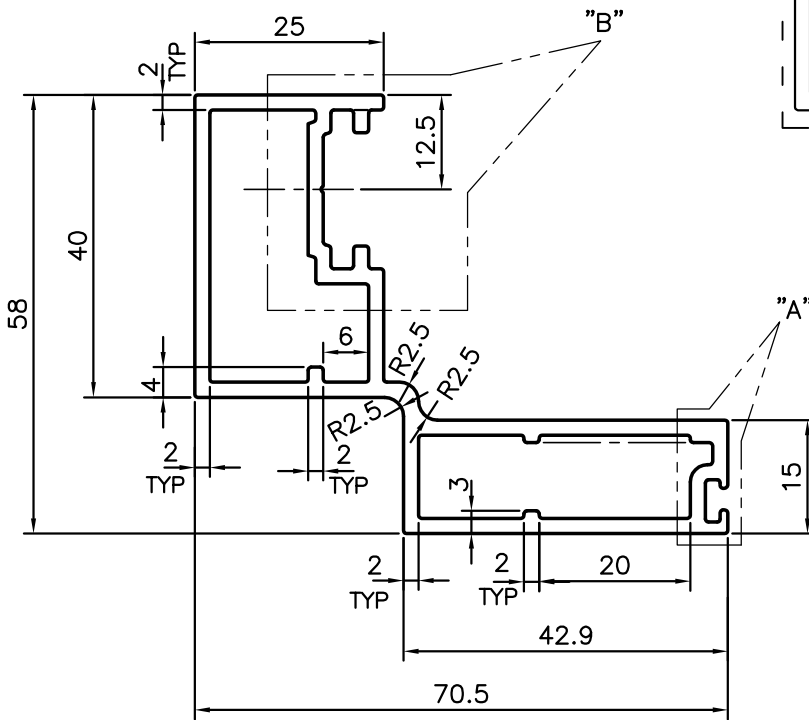

EXPOSED SURFACE

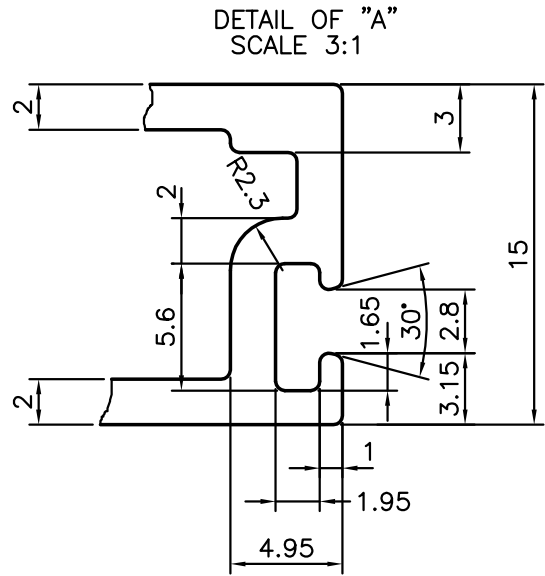
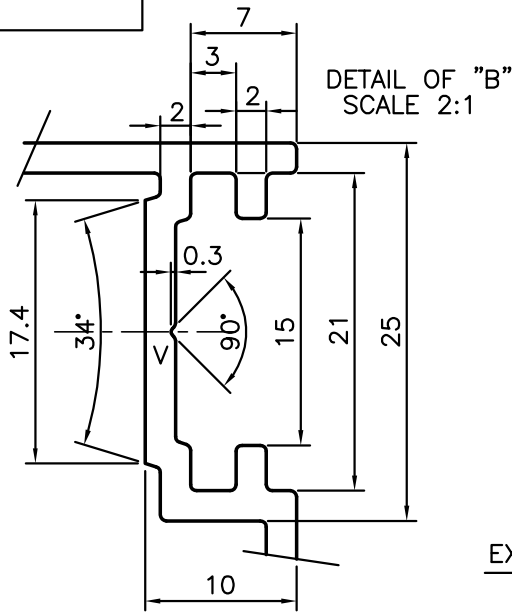
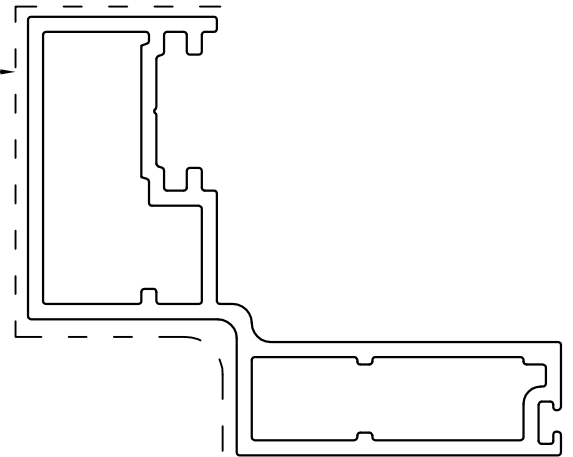

SYMBOL OF QUALITY  
AN ISO 9001 COMPANY

**JINDAL ALUMINIUM LTD.**  
BANGALORE-560073 (INDIA)

	NAME	DATE
DRAWN	J.P.KAUSHIK	22-03-2011
CHECKED		
APPROVED	S.S.GARG	08-07-2011
SCALE		1:1
AREA mm <sup>2</sup>		522.116
PERIMETER mm.		287.897
WEIGHT kg/m		1.410

1. ALL DIMENSIONS ARE IN mm.
2. ROUND OFF ALL SHARP CORNERS WITH 0.40 mm.
3. TOLERANCES WILL BE AS PER IS:6477-1983 UNLESS OTHERWISE SPECIFIED

PARTY'S NAME	ALUPRO BUILDING SYSTEMS (P) LTD.,BANGALORE
PARTY'S DRAWING No.	AS PER DRAWING
ALLOY & TEMPER	HE9 WP
DESCRIPTION	CURTAIN WALL SECTION

DRAWING No.	SECTION No.
P-10863	-
E0027	E0027