

P-11134-1

E0032

----- EXPOSED SURFACE

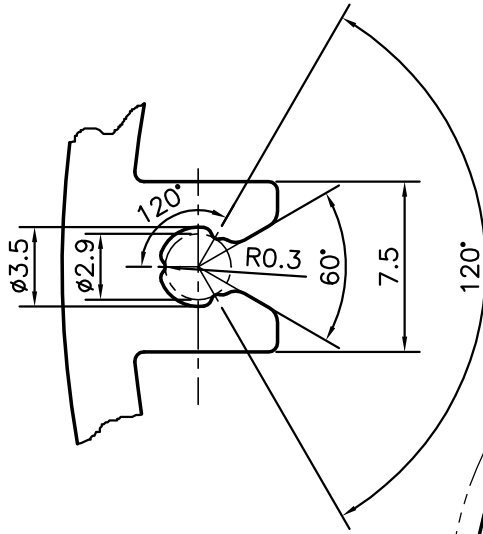

DETAIL OF "A"  
SCALE 3:1

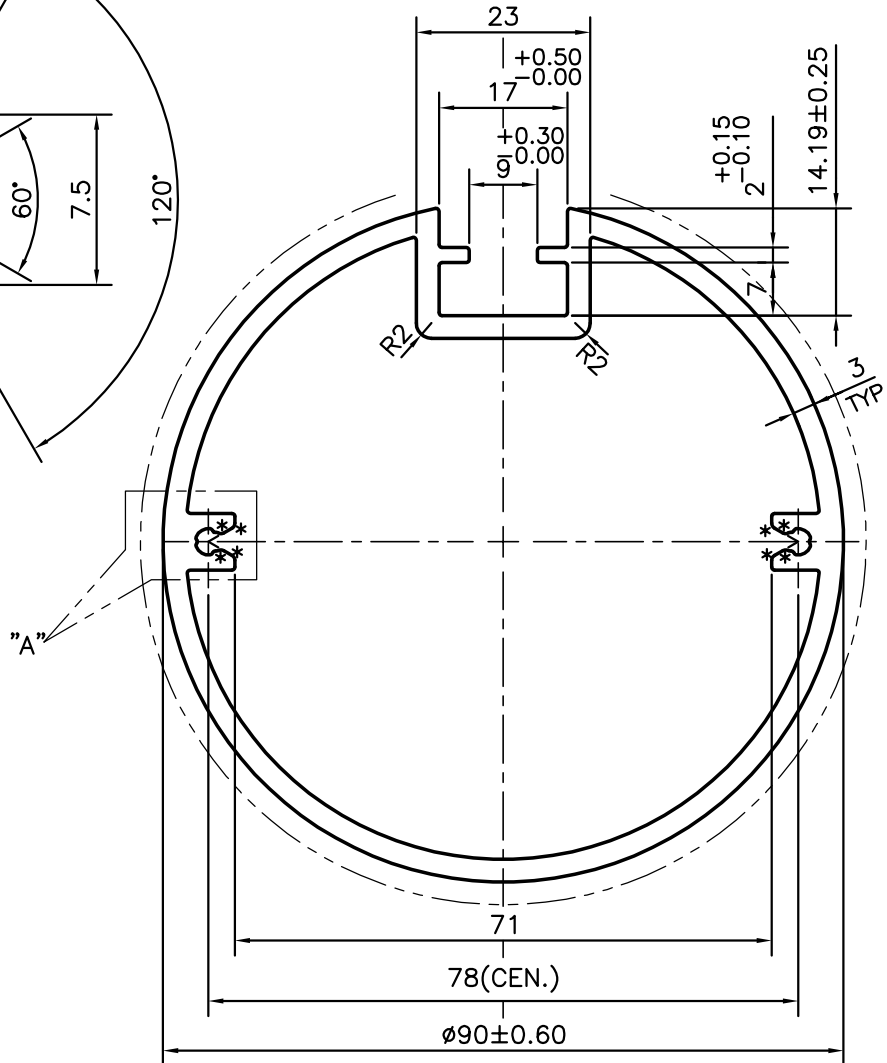

\* = 0.75 RADIUS (8 PLACES)



SYMBOL OF QUALITY  
AN ISO 9001 COMPANY

**JINDAL ALUMINIUM LTD.**  
BANGALORE-560073 (INDIA)

	NAME	DATE
DRAWN	J.P.KAUSHIK	11-08-2011
CHECKED		
APPROVED	S.S.GARG	18-08-2011
SCALE		1:1
AREA mm <sup>2</sup>		984.4
PERIMETER mm.		324.943
WEIGHT kg/m		2.658
DRAWING No.	SECTION No.	
P-11134-1	-	
E0032	E0032	

1. ALL DIMENSIONS ARE IN mm.
2. ROUND OFF ALL SHARP CORNERS WITH 0.40 mm.
3. TOLERANCES WILL BE AS PER BS:EN-755-9 UNLESS OTHERWISE SPECIFIED

PARTY'S NAME	COSIGN NV, BELGIUM
PARTY'S DRAWING No.	E23062
ALLOY & TEMPER	6060 T6
DESCRIPTION	MISC. SECTION