

P-11647-2

E0043

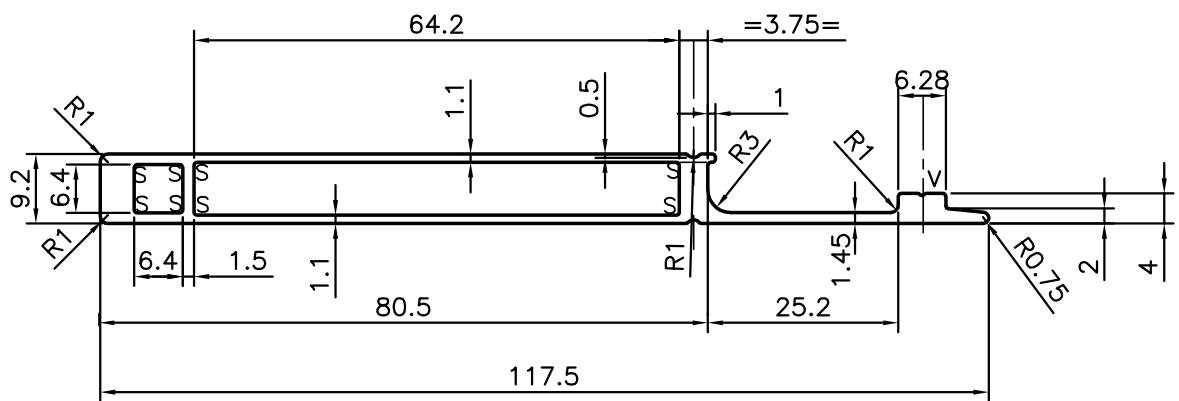

S = 0.4 RADIUS ( 8 PLACES )

V = V GROOVE 0.3x90°



SYMBOL OF QUALITY  
AN ISO 9001 COMPANY

**JINDAL ALUMINIUM LTD.**  
BANGALORE-560073 (INDIA)

	NAME	DATE
DRAWN	J.P.KAUSHIK	11-04-2012
CHECKED		
APPROVED	S.S.GARG	20-04-2012
SCALE		1:1
AREA mm <sup>2</sup>		321.628
PERIMETER mm.		256.623
WEIGHT kg/m		0.868
DRAWING No.	SECTION No.	
P-11647-2	-	
E0043	E0043	

1. ALL DIMENSIONS ARE IN mm.
2. ROUND OFF ALL SHARP CORNERS WITH 0.40 mm.
3. TOLERANCES WILL BE AS PER IS:6477-1983 UNLESS OTHERWISE SPECIFIED

PARTY'S NAME	YAMUNA ENTERPRISE, AHMEDABAD
PARTY'S DRAWING No.	AS PER SAMPLE
ALLOY & TEMPER	6063 T6
DESCRIPTION	TEXTILE SECTION