

P-11667

E0044

-

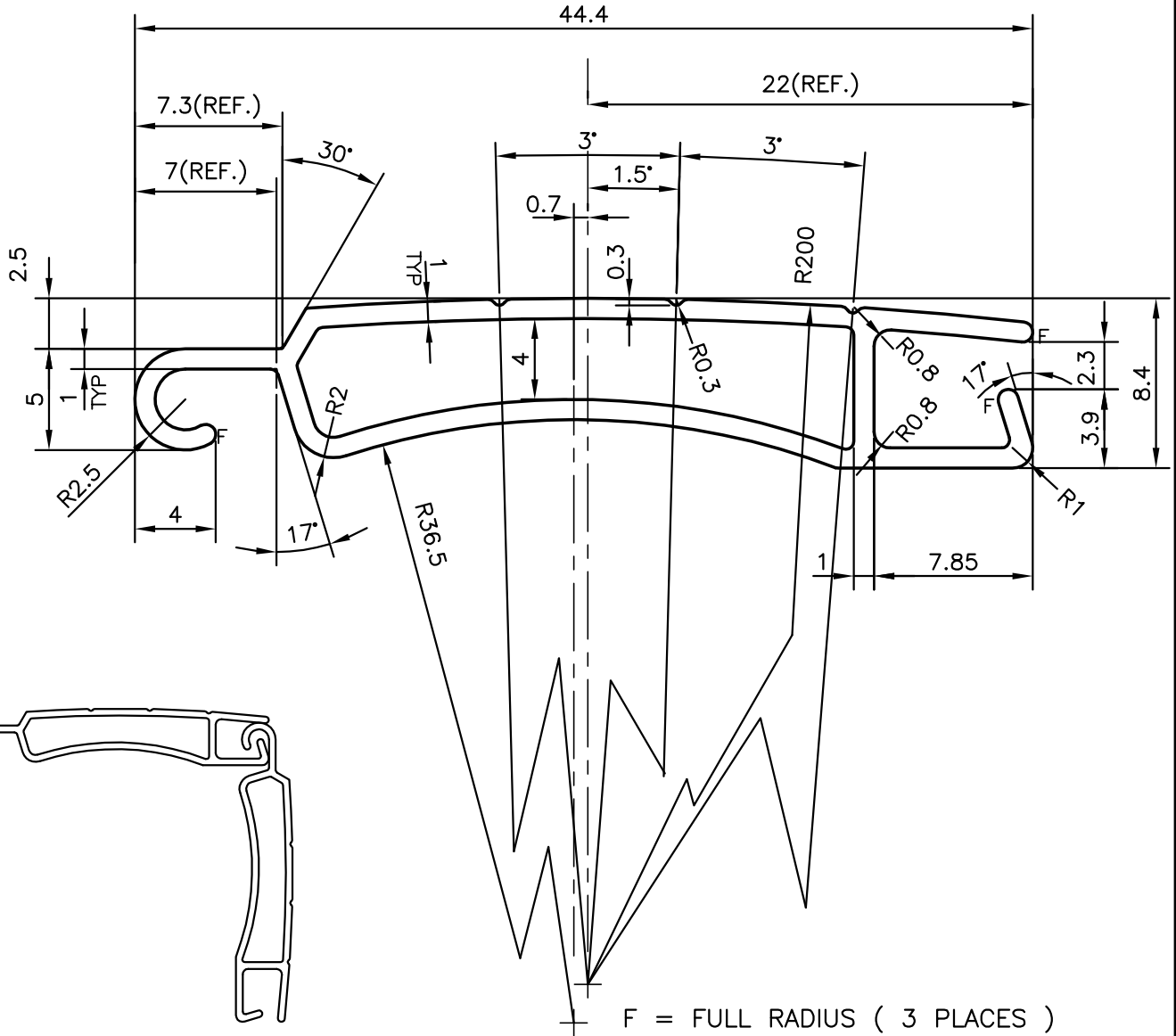

F = FULL RADIUS (3 PLACES)



SYMBOL OF QUALITY
AN ISO 9001 COMPANY

JINDAL ALUMINIUM LTD.
BANGALORE-560073 (INDIA)

| | NAME | DATE |
|----------------------|-------------|------------|
| DRAWN | J.P.KAUSHIK | 19-04-2012 |
| CHECKED | | |
| APPROVED | S.S.GARG | 21-04-2012 |
| SCALE | | 3:1 |
| AREA mm ² | | 99 |
| PERIMETER mm. | | 131.284 |
| WEIGHT kg/m | | 0.267 |
| DRAWING No. | SECTION No. | |
| P-11667 | - | |
| E0044 | E0044 | |
| - | - | |

1. ALL DIMENSIONS ARE IN mm.
2. ROUND OFF ALL SHARP CORNERS WITH 0.40 mm.
3. TOLERANCES WILL BE AS PER IS:6477-1983 UNLESS OTHERWISE SPECIFIED

| | |
|---------------------|-----------------------------|
| PARTY'S NAME | HANSPAL TRADERS, KAPURTHALA |
| PARTY'S DRAWING No. | AS PER SAMPLE |
| ALLOY & TEMPER | 63400 WP |
| DESCRIPTION | SHUTTER SECTION |