

P-11746
E0046
-

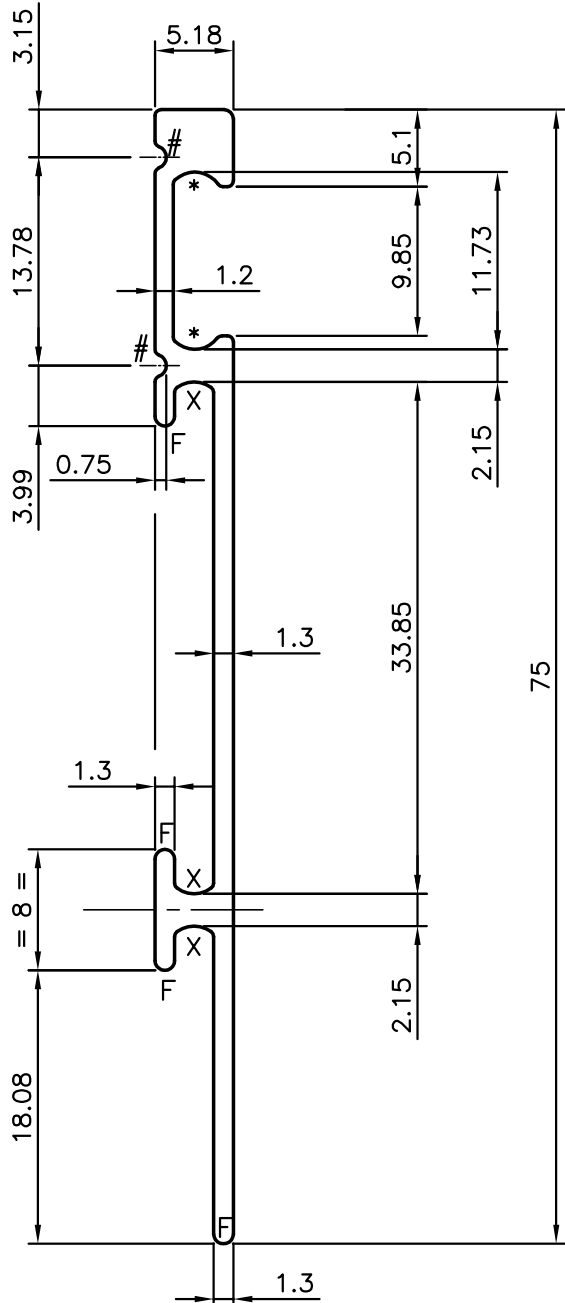

EXPOSED SURFACE

SCALE 1:1

THIS CLIP SHOULD NOT COME OUT

NOTE:-

1. F = FULL RADIUS (4 PLACES)
2. \* = R1.87 mm (2 PLACES)
3. X = R1.91 mm (3 PLACES)
4. # = R0.75 mm (2 PLACES)

 SYMBOL OF QUALITY AN ISO 9001 COMPANY	<b>JINDAL ALUMINIUM LTD.</b> BANGALORE-560073 (INDIA)	DRAWN	J.P.KAUSHIK	DATE	08-05-2012
		CHECKED			
1. ALL DIMENSIONS ARE IN mm. 2. ROUND OFF ALL SHARP CORNERS WITH 0.4 mm. 3. TOLERANCES WILL BE AS PER IS:3965-1981 UNLESS OTHERWISE SPECIFIED		APPROVED	J.N.RAI		21-05-2012
		SCALE			2:1
PARTY'S NAME SURFACES, B'LORE		AREA	mm <sup>2</sup>		142.103
		PERIMETER	mm.		191.024
PARTY'S DRAWING No. AS PER SPECIFICATION		WEIGHT	kg/m		0.384
		DRAWING No.		SECTION No.	
ALLOY & TEMPER HE9 WP		P-11746		-	
		E0046		E0046	
DESCRIPTION FURNITURE SECTION		-		-	