

THIS CLIP SHOULD NOT COME OUT

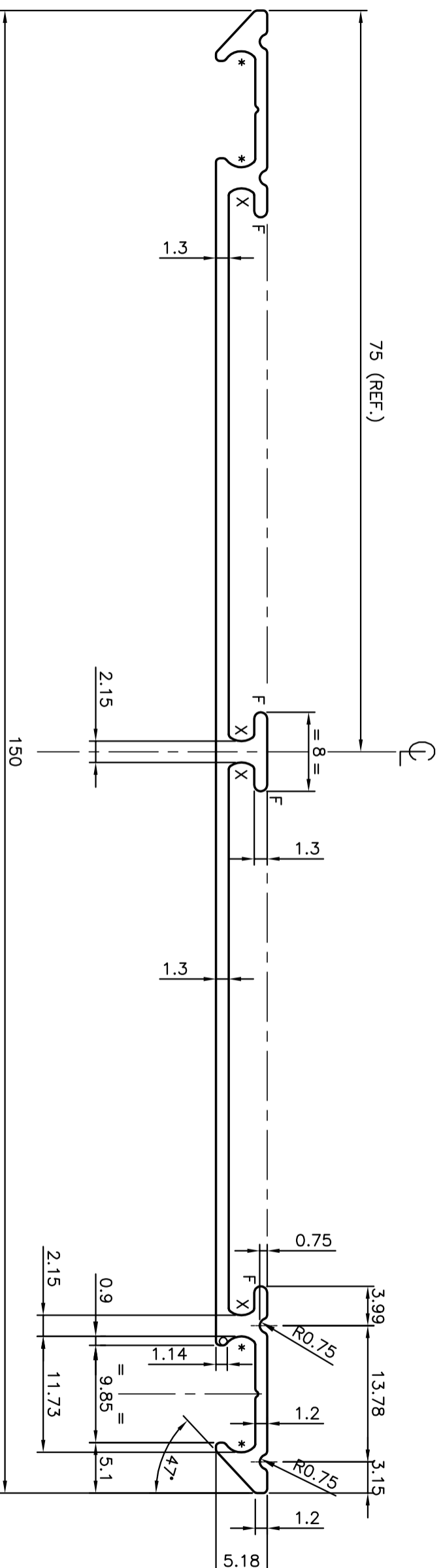
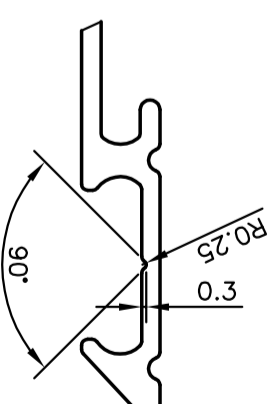
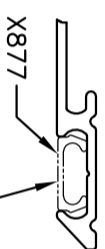

- NOTE:-
1. F = FULL RADIUS (4 PLACES)
 2. * = R1.87 mm (4 PLACES)
 3. X = R1.91 mm (4 PLACES)

<p>SYMBOL OF QUALITY AN ISO 9001 COMPANY</p>	<p>JINDAL ALUMINIUM LTD. BANGALORE-560073 (INDIA)</p>		NAME	DATE
	<p>1. ALL DIMENSIONS ARE IN mm. 2. ROUND OFF ALL SHARP CORNERS WITH 0.40 mm. 3. TOLERANCES WILL BE AS PER IS:3965-1981 UNLESS OTHERWISE SPECIFIED</p>	<p>DRAWN U.P.KAUSHIK CHECKED APPROVED J.N.RAJ</p>	<p>08-05-2012 21-05-2012</p>	
PARTY'S NAME	SURFACES, B'LORE		SCALE	2:1
PARTY'S DRAWING No.	AS PER SPECIFICATION		AREA mm ²	250.993
ALLOY & TEMPER	HE9 WP		PERIMETER mm.	359.826
DESCRIPTION	FURNITURE SECTION		WEIGHT kg/m	0.678
	DRAWING No.	SECTION No.		
	P-11750	-		
	E0050	E0050		