

P-11771-3

E0053

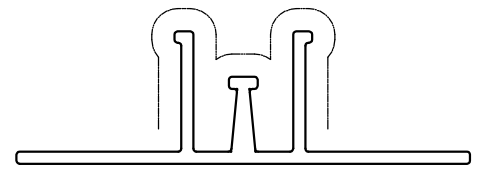

SCALE :- 1:1

EXPOSED SURFACE

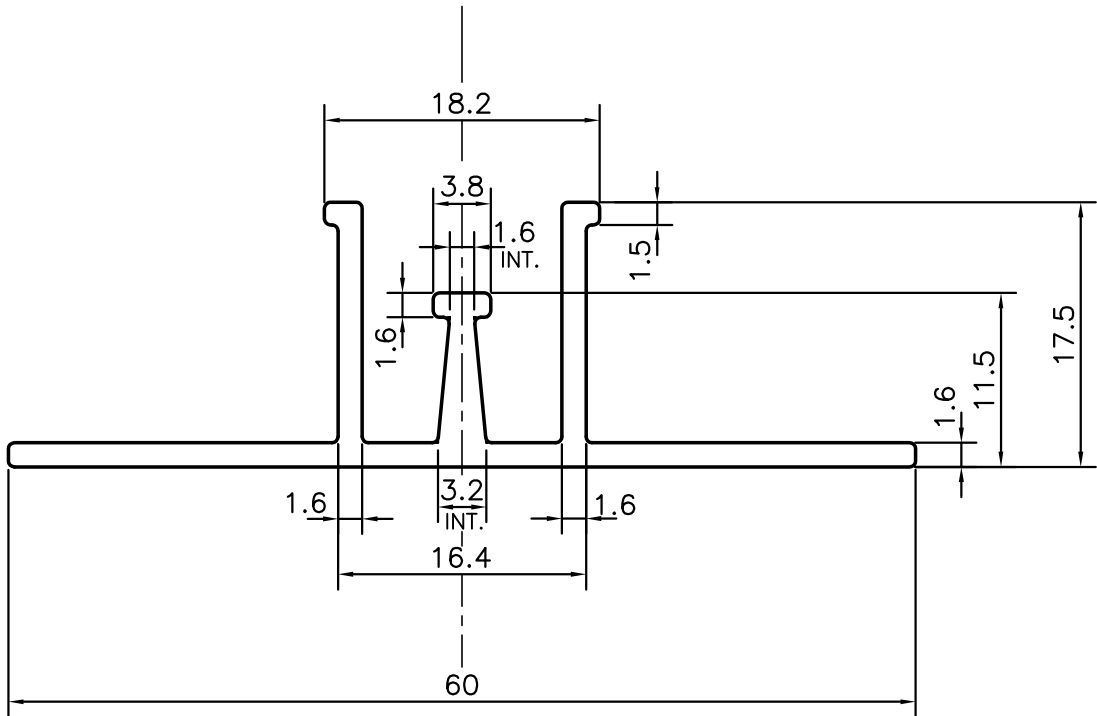

SYMBOL OF QUALITY
AN ISO 9001 COMPANY

JINDAL ALUMINIUM LTD.
BANGALORE-560073 (INDIA)

	NAME	DATE
DRAWN	PARVESH	11-06-2012
CHECKED		
APPROVED	S.S.GARG	14-06-2012
SCALE		2:1
AREA mm ²		175.446
PERIMETER mm.		208.942
WEIGHT kg/m		0.474
DRAWING No.	SECTION No.	
P-11771-3	-	
E0053	E0053	

1. ALL DIMENSIONS ARE IN mm.
2. ROUND OFF ALL SHARP CORNERS WITH 0.40 mm.
3. TOLERANCES WILL BE AS PER,BS:EN-755-9 UNLESS OTHERWISE SPECIFIED

PARTY'S NAME	GENSER ENGINEERING PROJECTS PVT. LTD., BANGALORE
PARTY'S DRAWING No.	AS PER DRAWING (ACET1)
ALLOY & TEMPER	HE9 WP
DESCRIPTION	FALSE CEILING SECTION