

P-11822-1

E0055

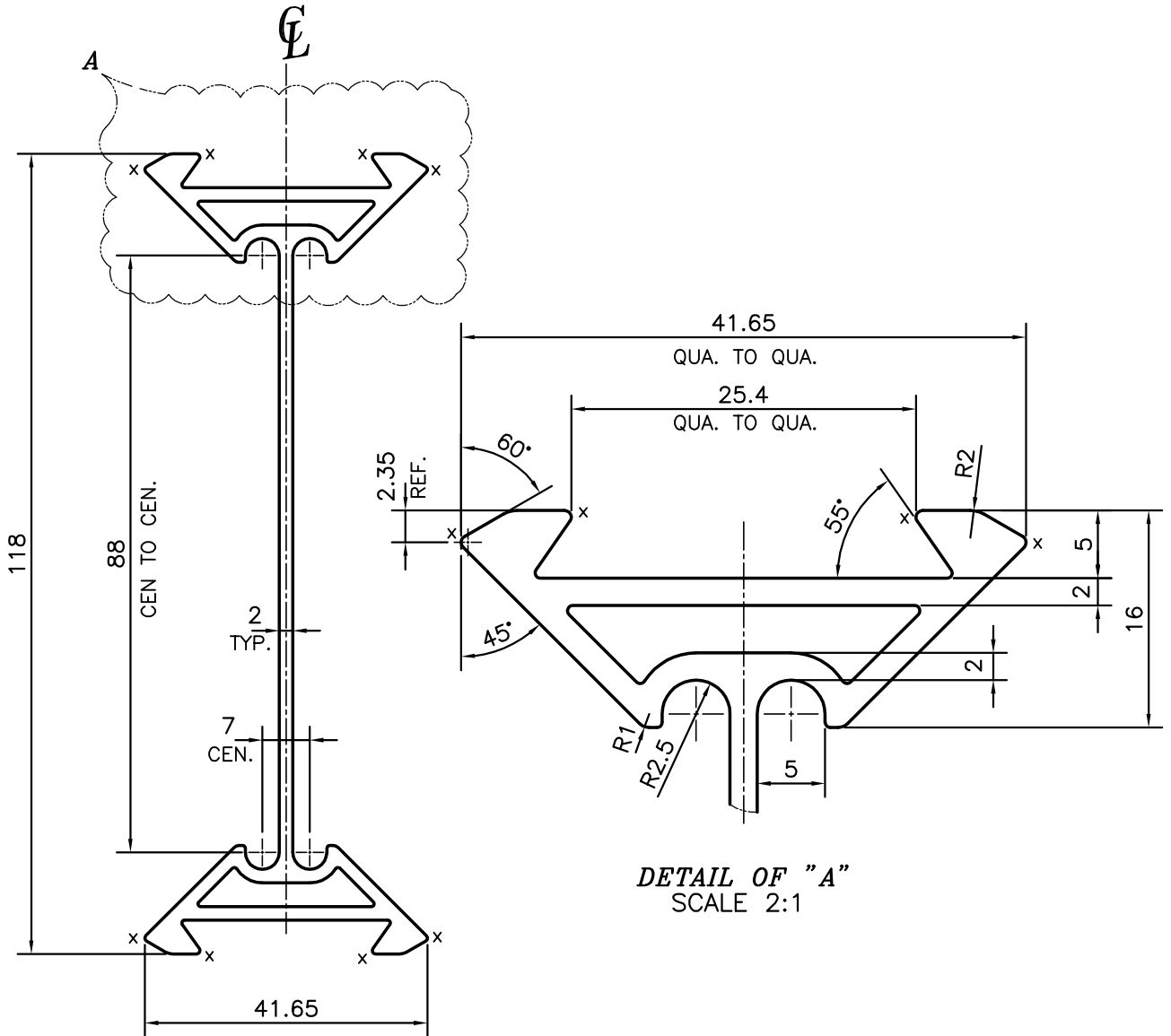

DETAIL OF "A"  
SCALE 2:1

X = RADIUS 0.5 mm. (8 PLACES)



SYMBOL OF QUALITY  
AN ISO 9001 COMPANY

**JINDAL ALUMINIUM LTD.**  
BANGALORE-560073 (INDIA)

	NAME	DATE
DRAWN	PARVESH	19-06-2012
CHECKED		
APPROVED	S.S.GARG	28-06-2012
SCALE		1:1
AREA mm <sup>2</sup>		600.477
PERIMETER mm.		411.666
WEIGHT kg/m		1.621
DRAWING No.	SECTION No.	
P-11822-1	-	
E0055	E0055	

1. ALL DIMENSIONS ARE IN mm.
2. ROUND OFF ALL SHARP CORNERS WITH 0.40 mm.
3. TOLERANCES WILL BE AS PER IS:6477-1983, UNLESS OTHERWISE SPECIFIED

PARTY'S NAME	SIEGER SPINTECH EQUIPMENT (P) LTD., COIMBATORE
PARTY'S DRAWING No.	16 9A XX 02 0A0
ALLOY & TEMPER	HE9 WP
DESCRIPTION	CONVEYOR SECTION