

P-11823-1

E0056

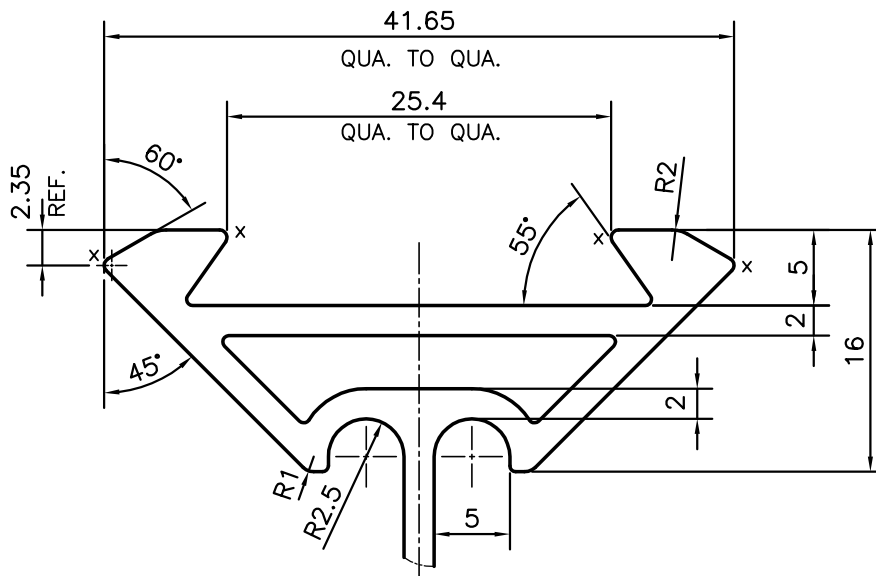
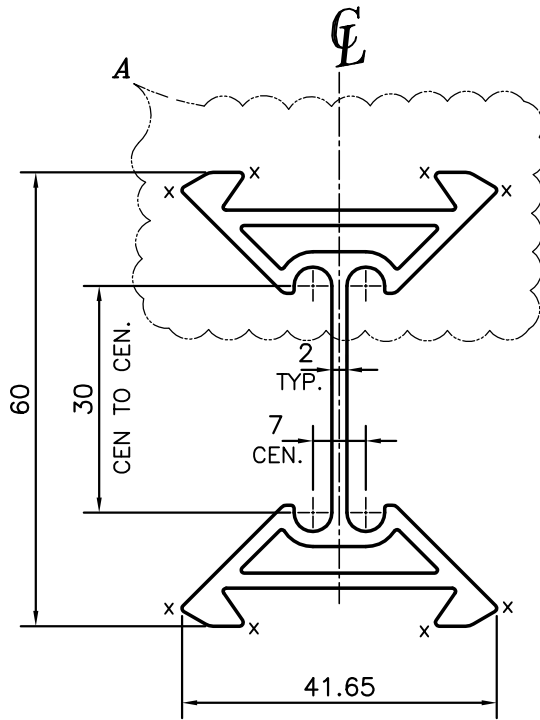

DETAIL OF "A"  
SCALE 2:1

X = RADIUS 0.5 mm. (8 PLACES)



SYMBOL OF QUALITY  
AN ISO 9001 COMPANY

**JINDAL ALUMINIUM LTD.**  
BANGALORE-560073 (INDIA)

	NAME	DATE
DRAWN	PARVESH	23-06-2012
CHECKED		
APPROVED	S.S.CARG	28-06-2012
SCALE		1:1
AREA mm <sup>2</sup>		484.477
PERIMETER mm.		295.666
WEIGHT kg/m		1.308
DRAWING No.		SECTION No.
P-11823-1		-
E0056		E0056

1. ALL DIMENSIONS ARE IN mm.
2. ROUND OFF ALL SHARP CORNERS WITH 0.40 mm.
3. TOLERANCES WILL BE AS PER IS:6477-1983, UNLESS OTHERWISE SPECIFIED

PARTY'S NAME	SIEGER SPINTECH EQUIPMENT (P) LTD.,
PARTY'S DRAWING No.	16 9A XX 03 0A0
ALLOY & TEMPER	HE9 WP
DESCRIPTION	CONVEYOR SECTION