

P-11829

E0061

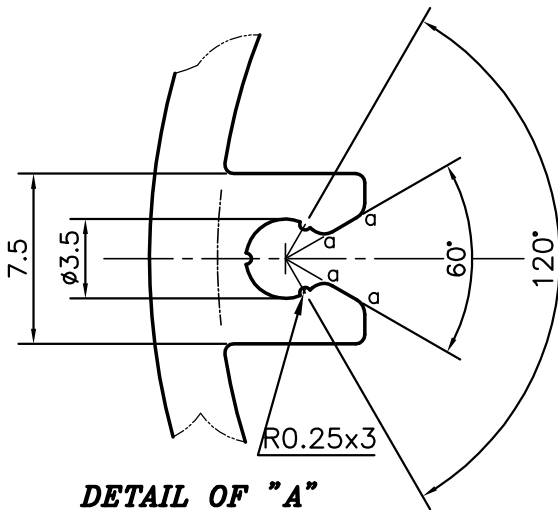
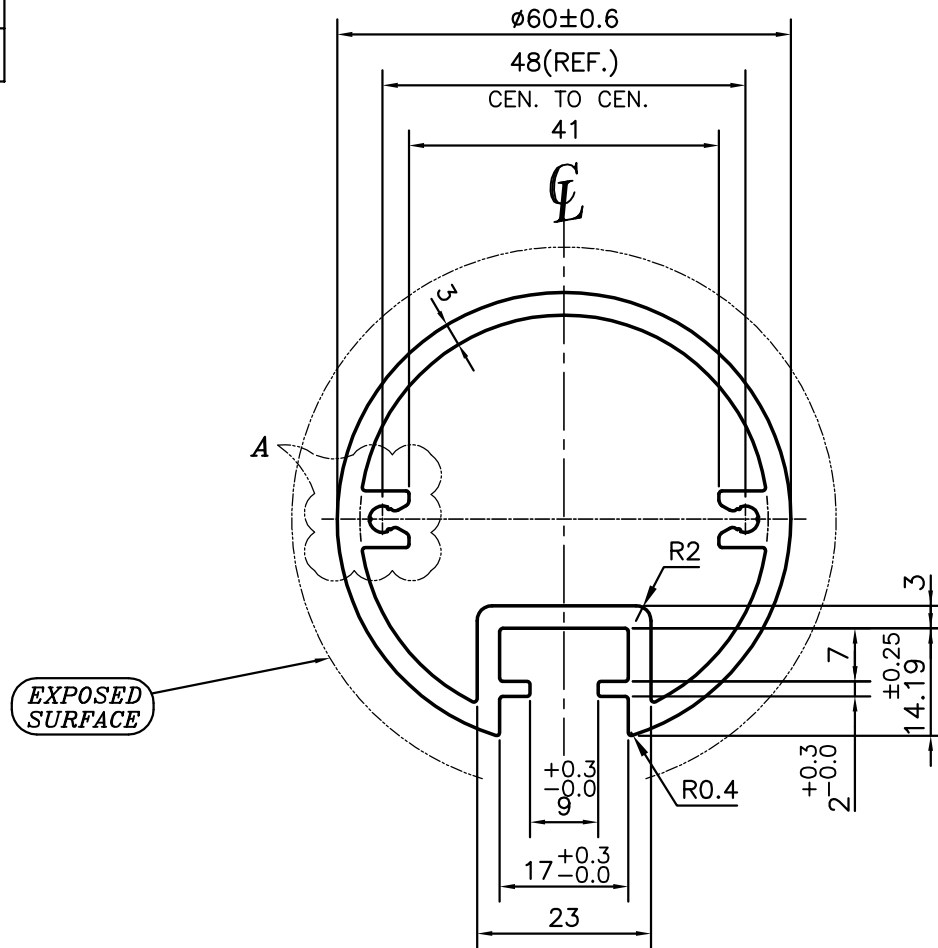

DETAIL OF "A"
SCALE 3:1

a = RADIUS 0.75 mm. (4 PLACES)



SYMBOL OF QUALITY
AN ISO 9001 COMPANY

JINDAL ALUMINIUM LTD.
BANGALORE-560073 (INDIA)

	NAME	DATE
DRAWN	PARVESH	16-06-2012
CHECKED		
APPROVED	S.S.GARG	07-08-2012
SCALE		1:1
AREA mm ²		698.795
PERIMETER mm.		230.536
WEIGHT kg/m		1.887
DRAWING No.	SECTION No.	
P-11829	-	
E0061	E0061	

1. ALL DIMENSIONS ARE IN mm.
2. ROUND OFF ALL SHARP CORNERS WITH 0.40 mm.
3. TOLERANCES WILL BE AS PER BS:EN-755-9, UNLESS OTHERWISE SPECIFIED

PARTY'S NAME	COSIGN INDIA PVT. LTD., PUNE
PARTY'S DRAWING No.	E23063
ALLOY & TEMPER	6060 T66
DESCRIPTION	DISPLAY SECTION