

P-12176

E0070

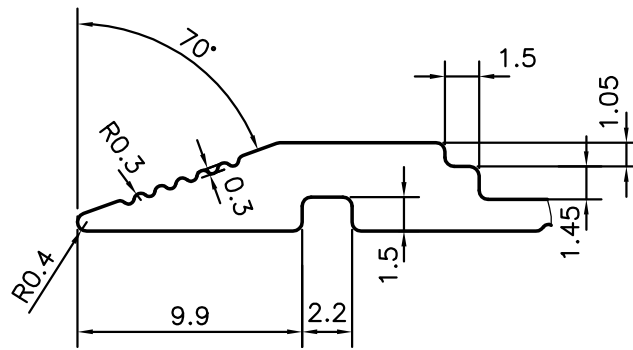

E0071

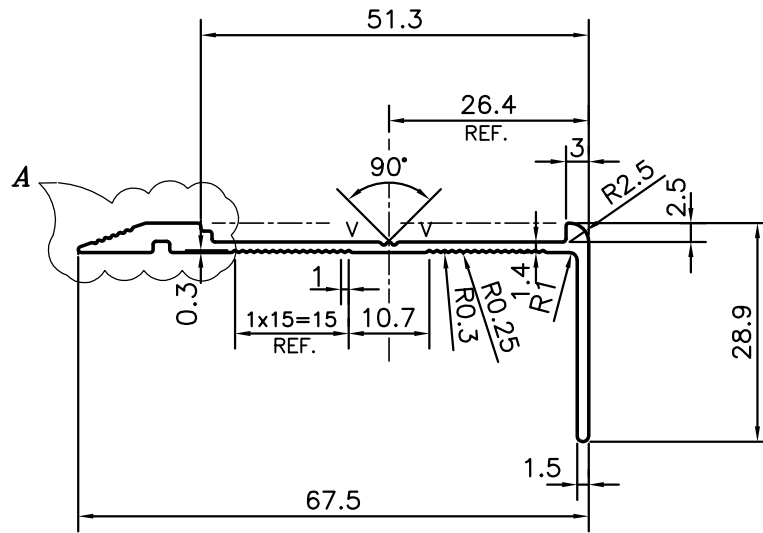
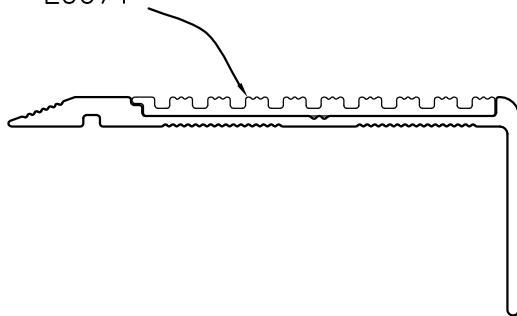

V = VEE GROOVE 0.4x90° (2 PLACE)



SYMBOL OF QUALITY
AN ISO 9001 COMPANY

JINDAL ALUMINIUM LTD.
BANGALORE-560073 (INDIA)

	NAME	DATE
DRAWN	PARVESH	22-10-2012
CHECKED		
APPROVED	S.S.GARG	12-11-2012
SCALE		1:1
AREA mm ²		157.21
PERIMETER mm.		202.972
WEIGHT kg/m		0.424
DRAWING No.	SECTION No.	
P-12176	-	
E0070	E0070	

1. ALL DIMENSIONS ARE IN mm.
2. ROUND OFF ALL SHARP CORNERS WITH 0.40 mm.
3. TOLERANCES WILL BE AS PER IS:3965-1981, UNLESS OTHERWISE SPECIFIED

PARTY'S NAME	SURFACES, BANGALORE
PARTY'S DRAWING No.	SAMPLE No.- 7
ALLOY & TEMPER	HE9 WP
DESCRIPTION	ARCHITECTURAL SECTION