

P-12140

E0077

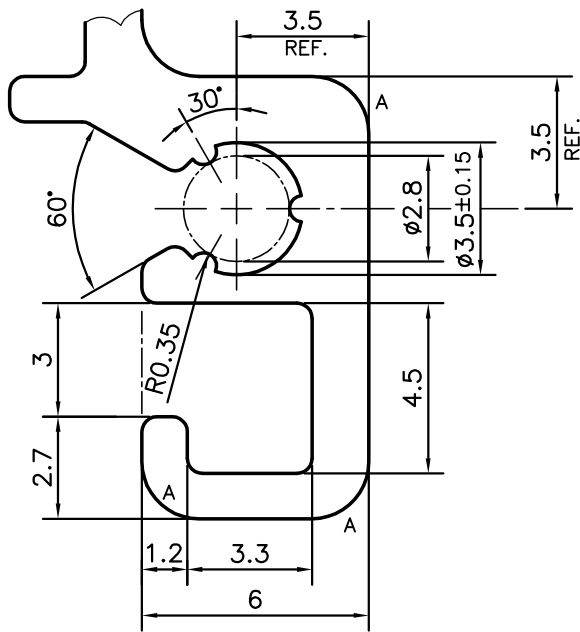
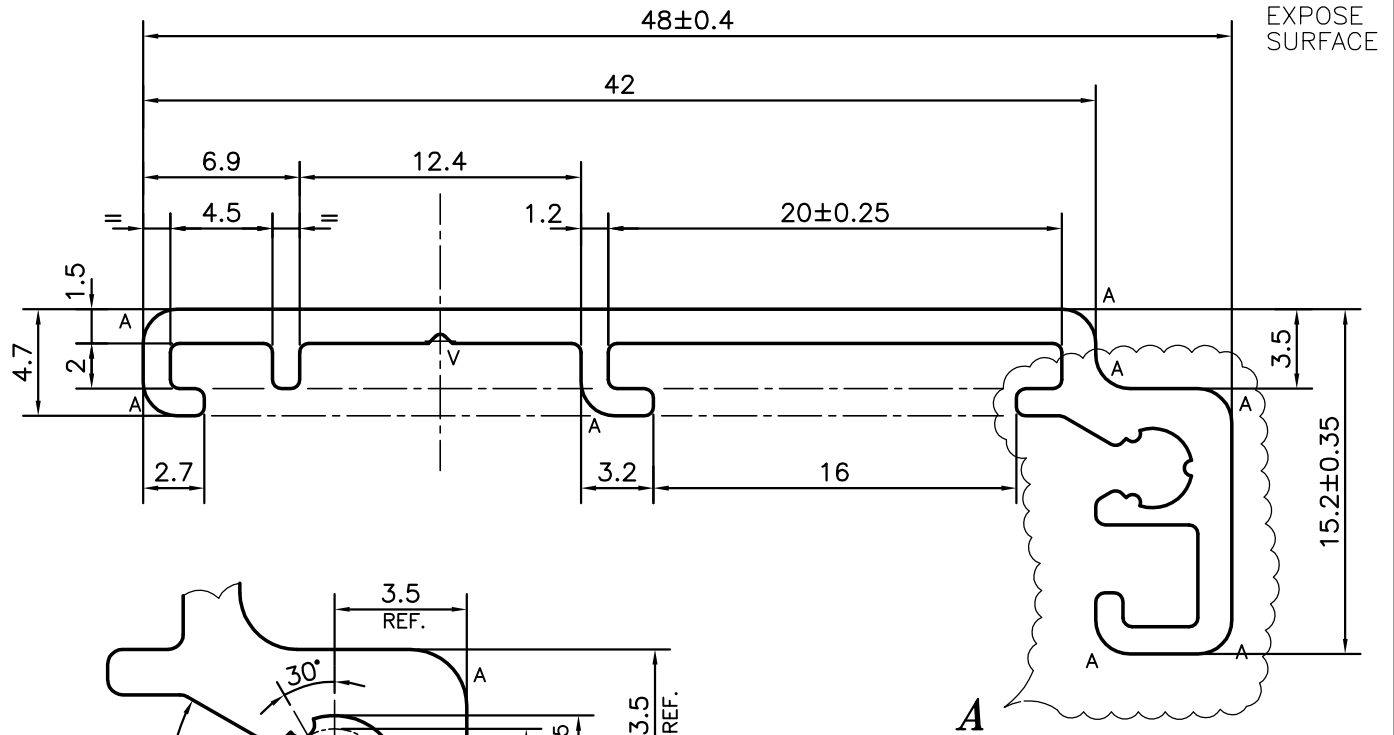
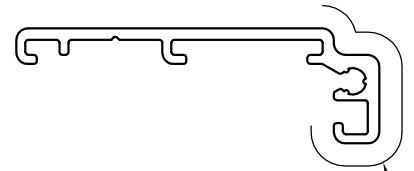

DETAIL OF "A"  
SCALE- 5:1

V = VEE GROOVE 0.4x90° (1 PLACE)  
A = RADIUS 1.5 mm. (8 PLACES)



SYMBOL OF QUALITY  
AN ISO 9001 COMPANY

**JINDAL ALUMINIUM LTD.**  
BANGALORE-560073 (INDIA)

	NAME	DATE
DRAWN	PARVESH	17-10-2012
CHECKED		
APPROVED	S.S.GARG	11-01-2013
SCALE		3:1
AREA mm <sup>2</sup>		122.616
PERIMETER mm.		165.993
WEIGHT kg/m		0.331
DRAWING No.	SECTION No.	
P-12140	-	
E0077	E0077	

1. ALL DIMENSIONS ARE IN mm.
2. ROUND OFF ALL SHARP CORNERS WITH 0.40 mm.
3. TOLERANCES WILL BE AS PER IS:3965-1981 UNLESS OTHERWISE SPECIFIED

PARTY'S NAME	COSIGN NV, BELGIUM
PARTY'S DRAWING No.	10/20149
ALLOY & TEMPER	6060 T66
DESCRIPTION	FURNITURE SECTION