

P-12200

E0078

EXPOSED SURFACE

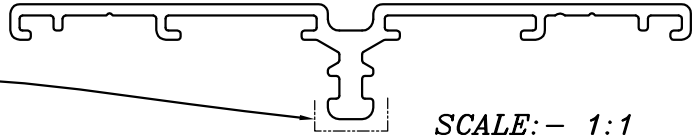

SCALE:- 1:1

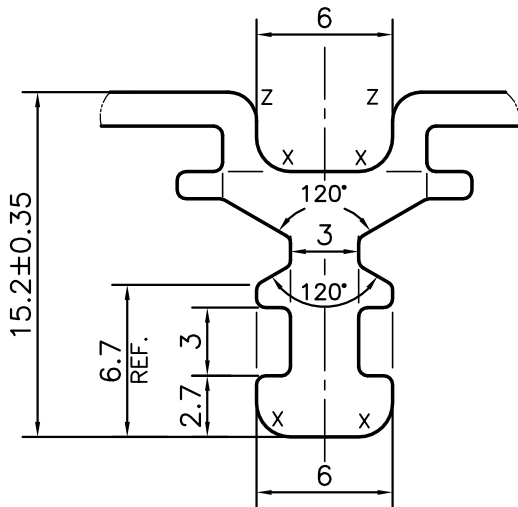
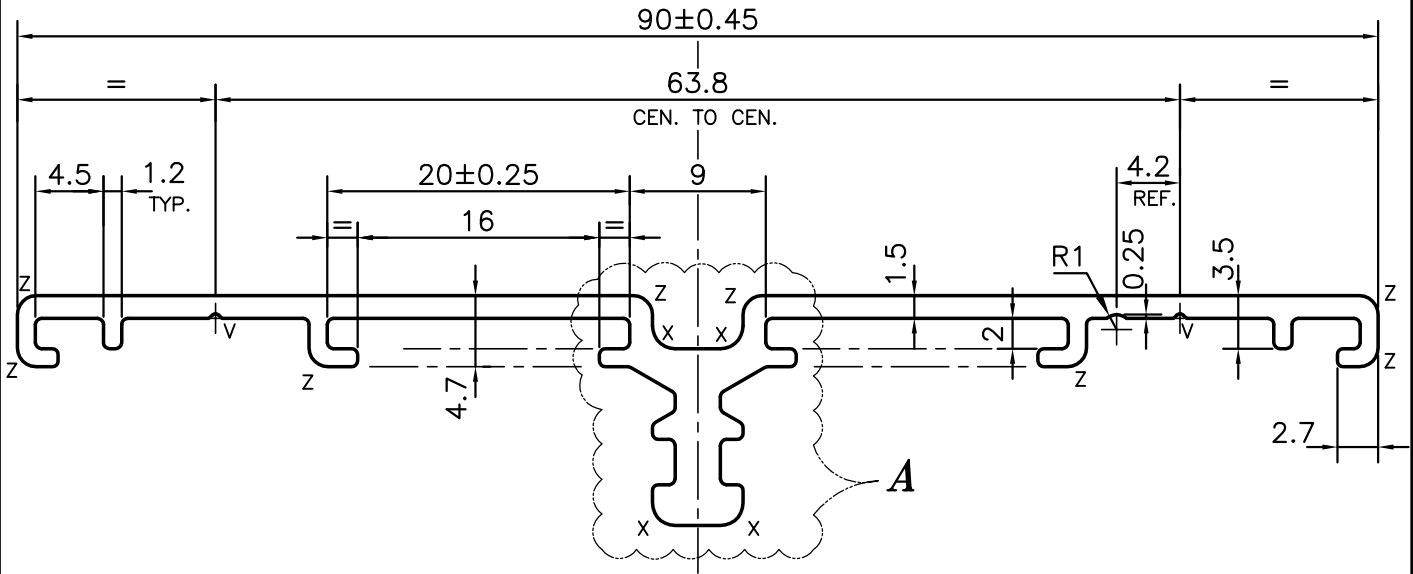

DETAIL OF "A"
SCALE:- 3:1

V = VEE GROOVE 0.3x90° (2 PLACES)

X = RADIUS 1.5 (4 PLACES)

Z = RADIUS 1.25 (8 PLACES)



SYMBOL OF QUALITY
AN ISO 9001 COMPANY

JINDAL ALUMINIUM LTD.
BANGALORE-560073 (INDIA)

| | NAME | DATE |
|----------------------|-------------|------------|
| DRAWN | PARVESH | 02-11-2012 |
| CHECKED | | |
| APPROVED | S.S.GARG | 11-01-2013 |
| SCALE | | 2:1 |
| AREA mm ² | | 222.112 |
| PERIMETER mm. | | 267.418 |
| WEIGHT kg/m | | 0.600 |
| DRAWING No. | SECTION No. | |
| P-12200 | - | |
| E0078 | E0078 | |
| | | |
| | | |

1. ALL DIMENSIONS ARE IN mm.
2. ROUND OFF ALL SHARP CORNERS WITH 0.40 mm.
3. TOLERANCES WILL BE AS PER BS:EN-12020-2, UNLESS OTHERWISE SPECIFIED

| | |
|---------------------|--------------------|
| PARTY'S NAME | COSIGN NV, BELGIUM |
| PARTY'S DRAWING No. | Dn° D2009_0530 |
| ALLOY & TEMPER | 6060 T66 |
| DESCRIPTION | DISPLAY SECTION |