

P-12381-1

E0082

EXPOSED SURFACE

SCALE: - 1:1

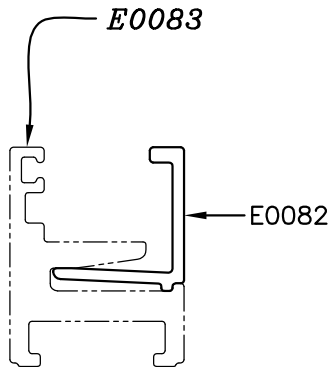
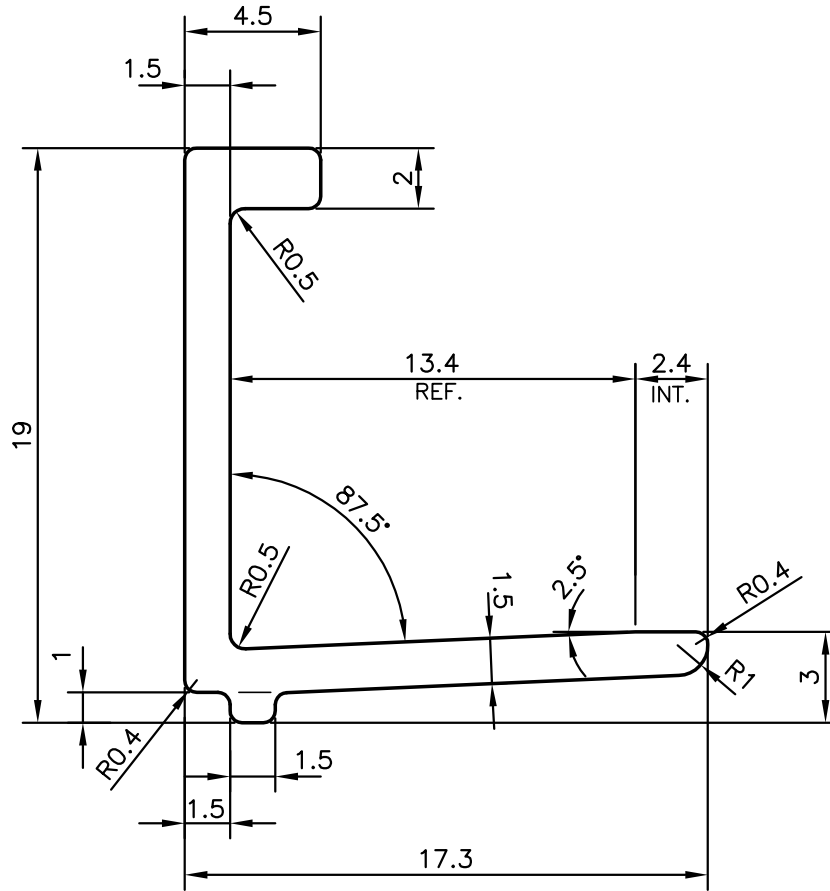

SYMBOL OF QUALITY
AN ISO 9001 COMPANY

JINDAL ALUMINIUM LTD.
BANGALORE-560073 (INDIA)

| | NAME | DATE |
|----------------------|-------------|------------|
| DRAWN | PARVESH | 02-01-2013 |
| CHECKED | | |
| APPROVED | S.S.GARG | 11-03-2013 |
| SCALE | | 4:1 |
| AREA mm ² | | 57.76 |
| PERIMETER mm. | | 76.219 |
| WEIGHT kg/m | | 0.156 |
| DRAWING No. | SECTION No. | |
| P-12381-1 | - | |
| E0082 | E0082 | |
| | | |
| | | |

1. ALL DIMENSIONS ARE IN mm.
2. ROUND OFF ALL SHARP CORNERS WITH 0.40 mm.
3. TOLERANCES WILL BE AS PER BS:EN-12020-2 , UNLESS OTHERWISE SPECIFIED

| | |
|---------------------|--------------------------------|
| PARTY'S NAME | DORMA INDIA PVT. LTD., CHENNAI |
| PARTY'S DRAWING No. | 80724200100 |
| ALLOY & TEMPER | 6060 T66 |
| DESCRIPTION | CLAMPING PROFILE |