

P-12387-1

E0087

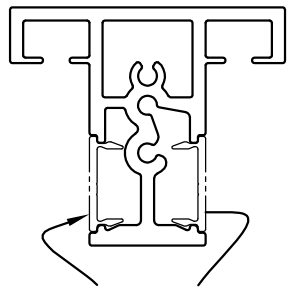

E0081

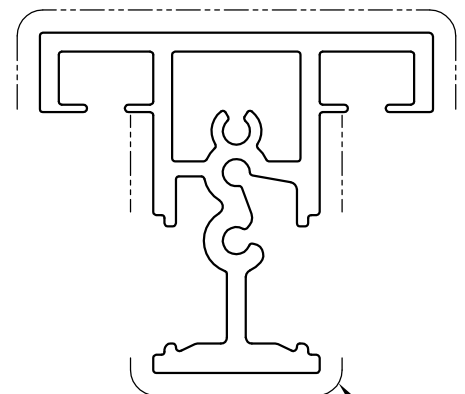

SCALE:- 1:1

EXPOSED SURFACE

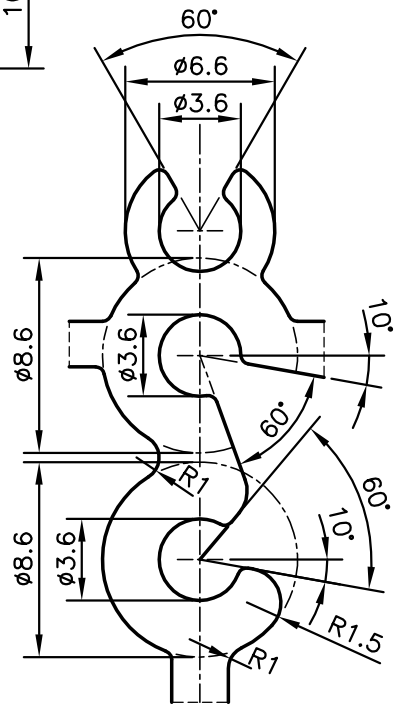
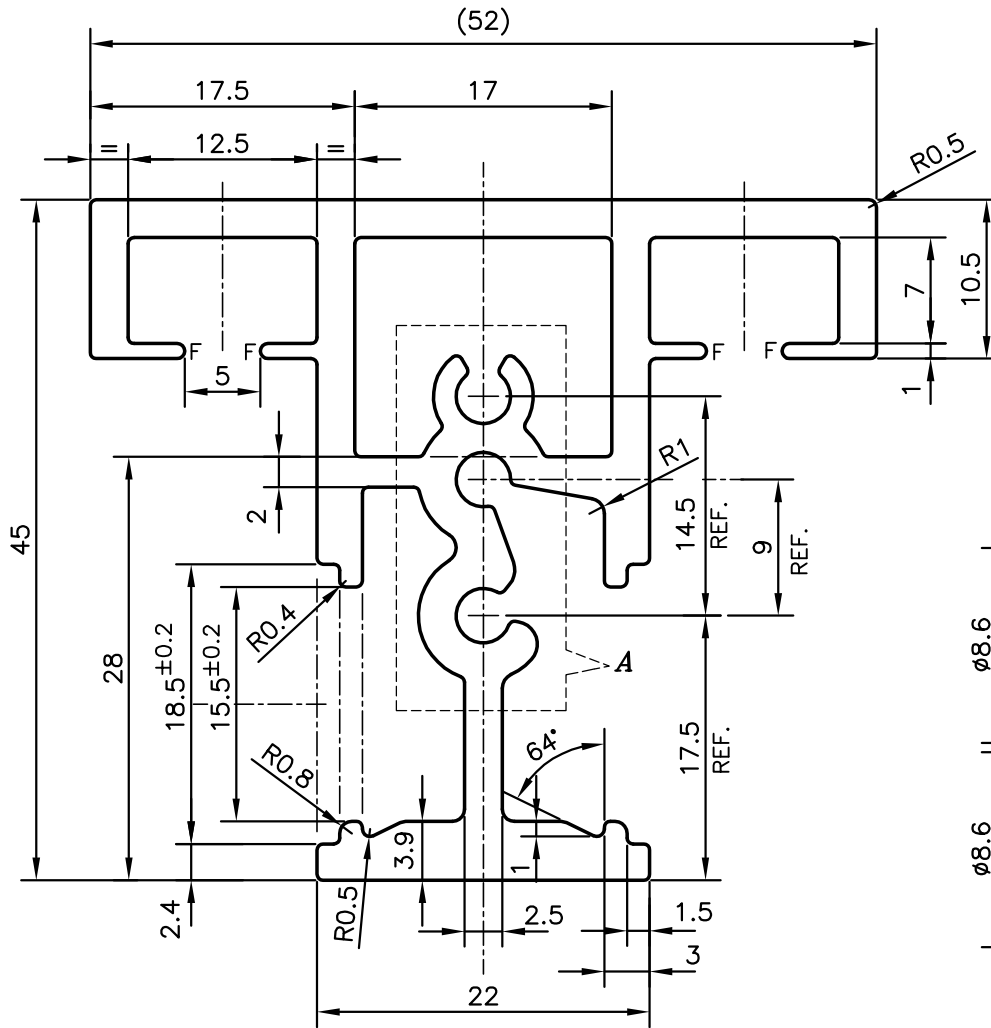

DETAIL OF "A"
SCALE 3:1

F = FULL RADIUS (4 PLACES)



SYMBOL OF QUALITY
AN ISO 9001 COMPANY

JINDAL ALUMINIUM LTD.
BANGALORE-560073 (INDIA)

	NAME	DATE
DRAWN	PARVESH	02-01-2013
CHECKED		
APPROVED	S.S.GARG	11-03-2013
SCALE		2:1
AREA mm ²		516.254
PERIMETER mm.		331.307
WEIGHT kg/m		1.394
DRAWING No.	SECTION No.	
P-12387-1	-	
E0087	E0087	

1. ALL DIMENSIONS ARE IN mm.
2. ROUND OFF ALL SHARP CORNERS WITH 0.40 mm.
3. TOLERANCES WILL BE AS PER BS:EN-12020-2 , UNLESS OTHERWISE SPECIFIED

PARTY'S NAME	DORMA INDIA PVT. LTD., CHENNAI
PARTY'S DRAWING No.	83201100100
ALLOY & TEMPER	6060 T66
DESCRIPTION	CENTRE MUNTIN PROFILE