

P-12362-1

E0088

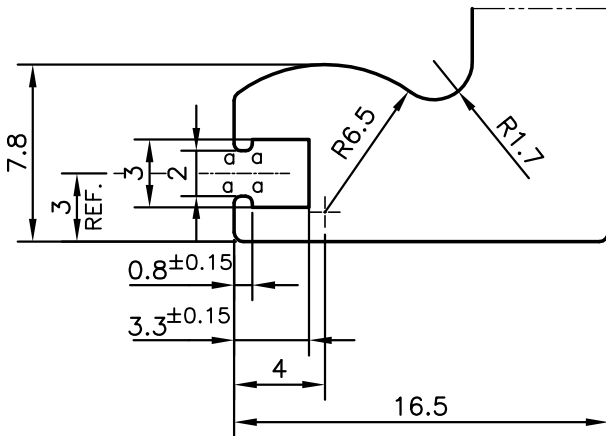

DETAIL OF "A"
SCALE 3:1

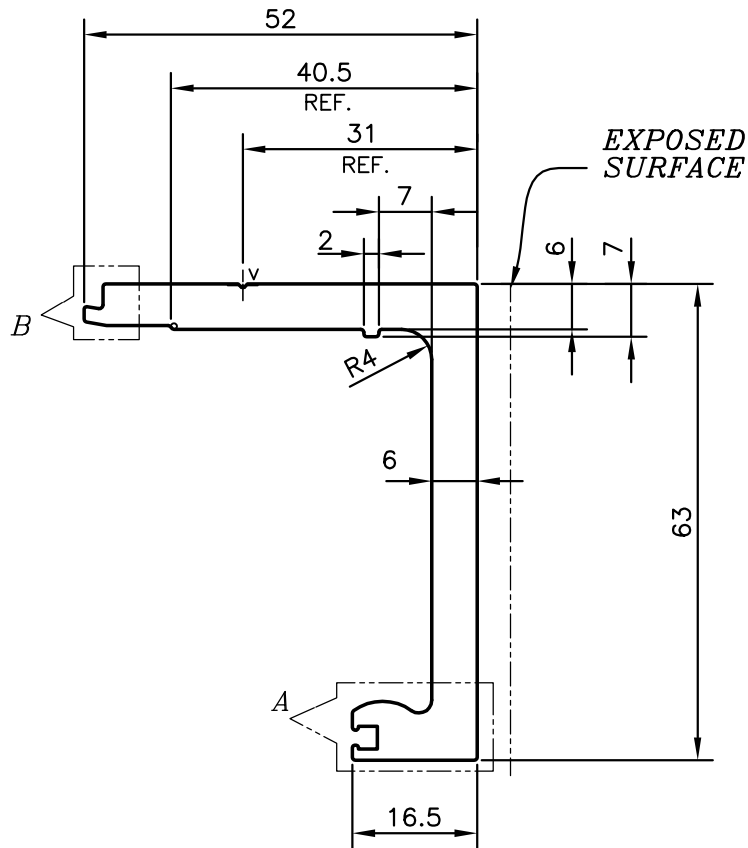
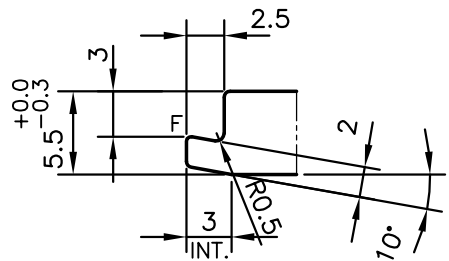

DETAIL OF "B"
SCALE 2:1

V = VEE GROOVE 0.5x90° (1 PLACE)
 F = FULL RADIUS (1 PLACE)
 a = RADIUS 0.3 mm (4 PLACES)



SYMBOL OF QUALITY
AN ISO 9001 COMPANY

JINDAL ALUMINIUM LTD.
BANGALORE-560073 (INDIA)

	NAME	DATE
DRAWN	PARVESH	02-01-2013
CHECKED		
APPROVED	S.S.GARG	18-03-2013
SCALE		1:1
AREA mm ²		710.504
PERIMETER mm.		257.509
WEIGHT kg/m		1.918
DRAWING No.	SECTION No.	
P-12362-1	-	
E0088	E0088	

1. ALL DIMENSIONS ARE IN mm.
2. ROUND OFF ALL SHARP CORNERS WITH 0.40 mm.
3. TOLERANCES WILL BE AS PER BS:EN-12020-2 , UNLESS OTHERWISE SPECIFIED

PARTY'S NAME	DORMA INDIA PVT. LTD., CHENNAI
PARTY'S DRAWING No.	80715800200
ALLOY & TEMPER	6060 T66
DESCRIPTION	MISC. SECTION