

P-12385-2

E0095

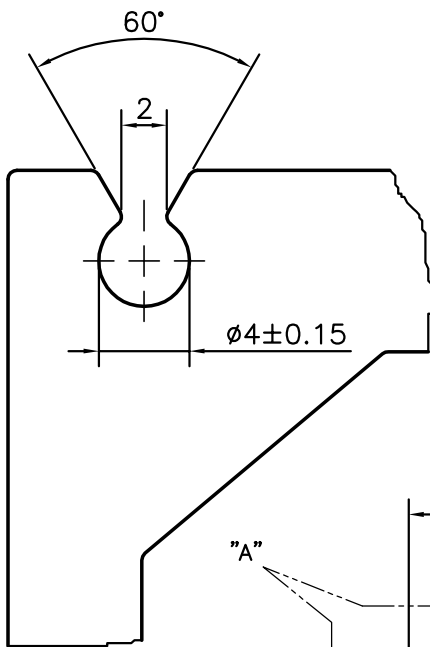

DETAIL "A"
SCALE 3:1

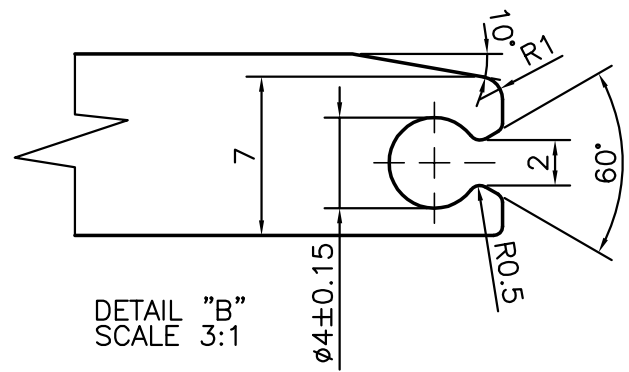

DETAIL "B"
SCALE 3:1

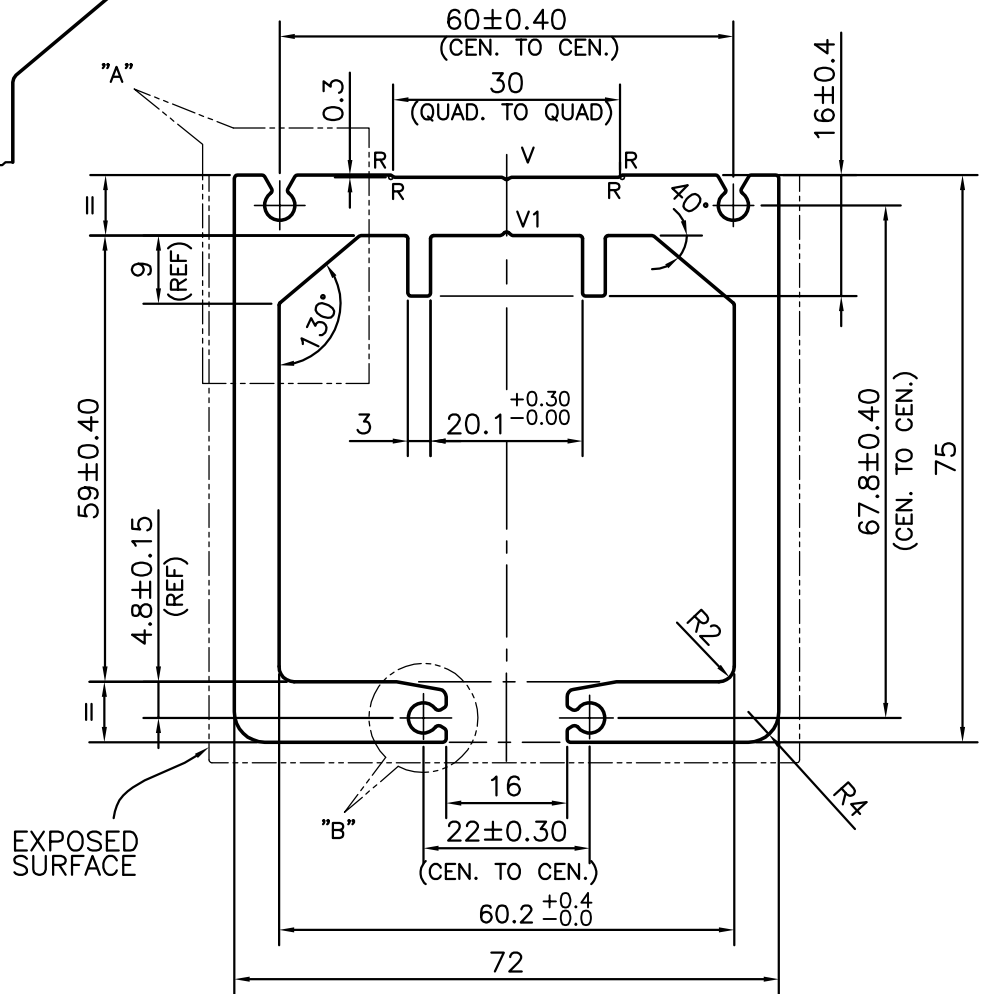

EXPOSED SURFACE

R = 0.3mm RADIUS (4 PLACES)
 V = 0.3x90° V-GROOVE (1 PLACE)
 V1 = 0.5x90° V-GROOVE (1 PLACE)



SYMBOL OF QUALITY
AN ISO 9001 COMPANY

JINDAL ALUMINIUM LTD.
 BANGALORE-560073 (INDIA)

	NAME	DATE
DRAWN	SRIVATHSA	19-02-2013
CHECKED		
APPROVED	S.S.GARG	18-03-2013
SCALE		1:1
AREA	mm ²	1773.569
PERIMETER	mm.	570.299
WEIGHT	kg/m	4.789
DRAWING No.	SECTION No.	
P-12385-2	-	
E0095	E0095	

1. ALL DIMENSIONS ARE IN mm.
2. ROUND OFF ALL SHARP CORNERS WITH 0.40 mm.
3. TOLERANCES WILL BE AS PER BS:EN-12020-2 , UNLESS OTHERWISE SPECIFIED

PARTY'S NAME	DORMA INDIA PVT LTD., CHENNAI
PARTY'S DRAWING No.	8.15.241.001.00
ALLOY & TEMPER	6060 T66
DESCRIPTION	TRACK PROFILE