

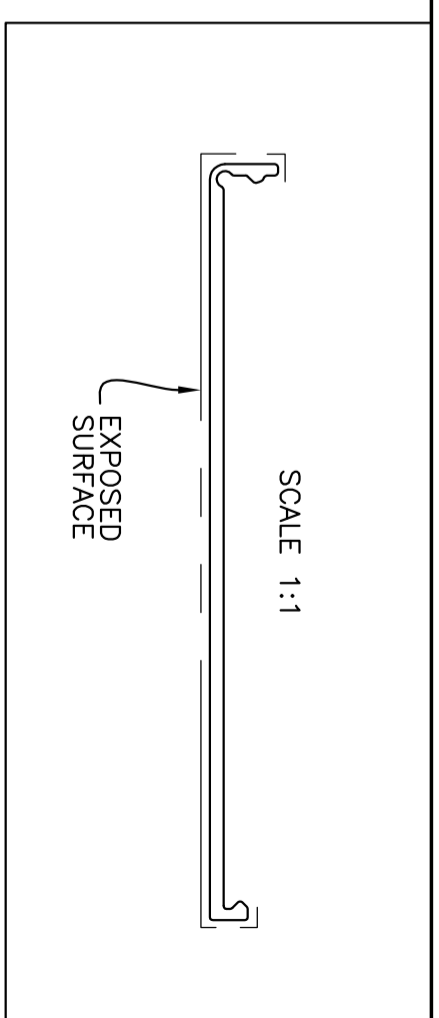

P-12390-2

E0096

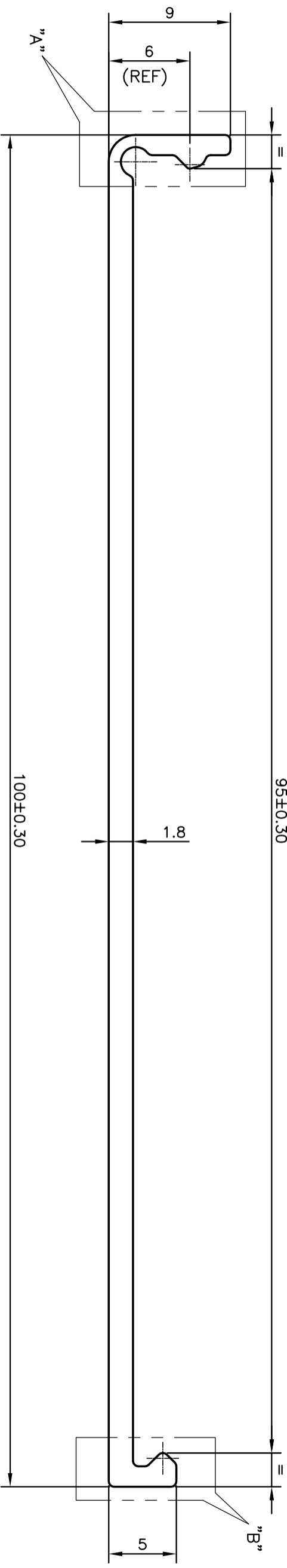
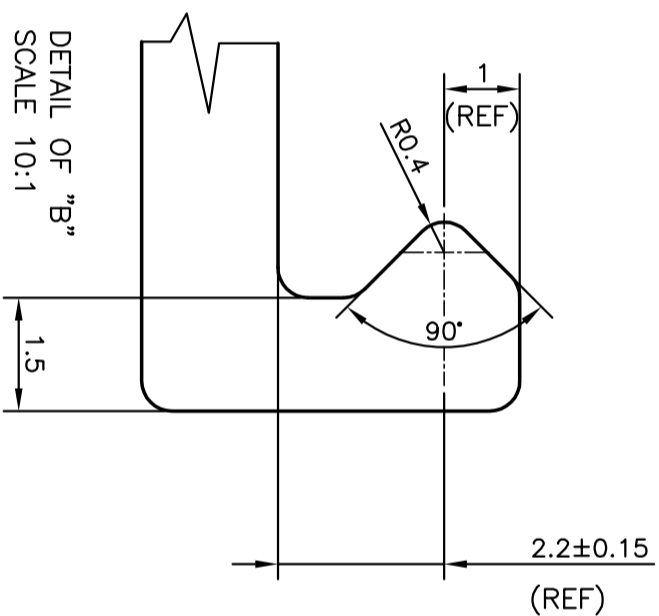
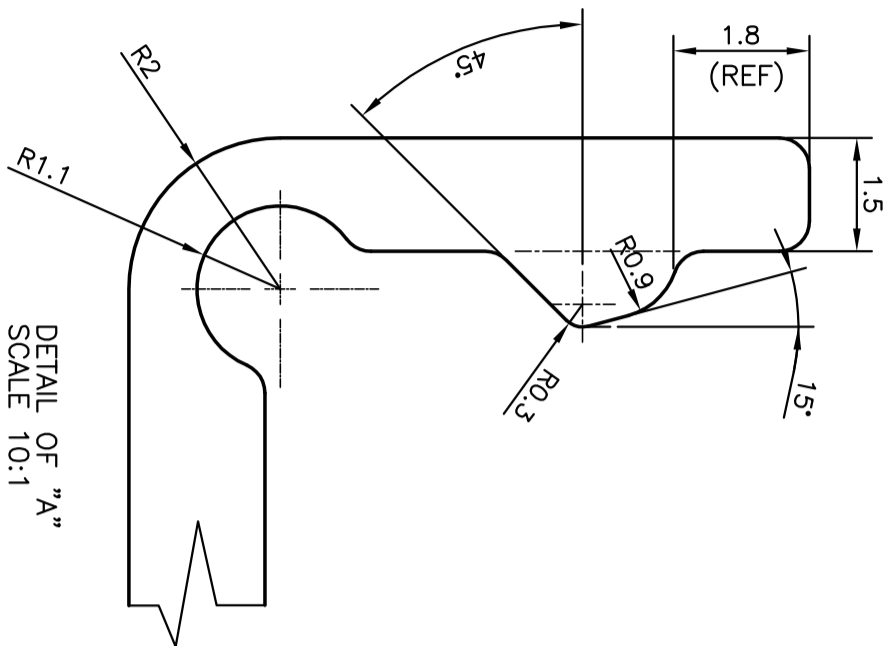

 <p>SYMBOL OF QUALITY AN ISO 9001 COMPANY</p>		<p>JINDAL ALUMINIUM LTD. BANGALORE-560073 (INDIA)</p>		NAME	DATE
				DRAWN	SRIYATHSA
<p>1. ALL DIMENSIONS ARE IN mm. 2. ROUND OFF ALL SHARP CORNERS WITH 0.40 mm. 3. TOLERANCES WILL BE AS PER BS:EN-12020-2, UNLESS OTHERWISE SPECIFIED</p>		<p>SCALE 3:1</p>		CHECKED	
				APPROVED	S.S.GARG
PARTY'S NAME		DORMA INDIA PVT LTD., CHENNAI		AREA	mm ²
PARTY'S DRAWING No.		8.04.013.001.00		PERIMETER	mm.
ALLOY & TEMPER		6060 T66		WEIGHT	kg/m
DESCRIPTION		COVER PROFILE		DRAWING No.	SECTION No.
				P-12390-2	-
				E0096	E0096