

E0098

E0096

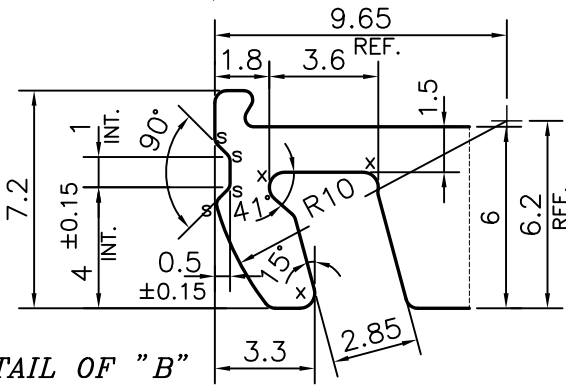

DETAIL OF "B"  
SCALE:- 4:1

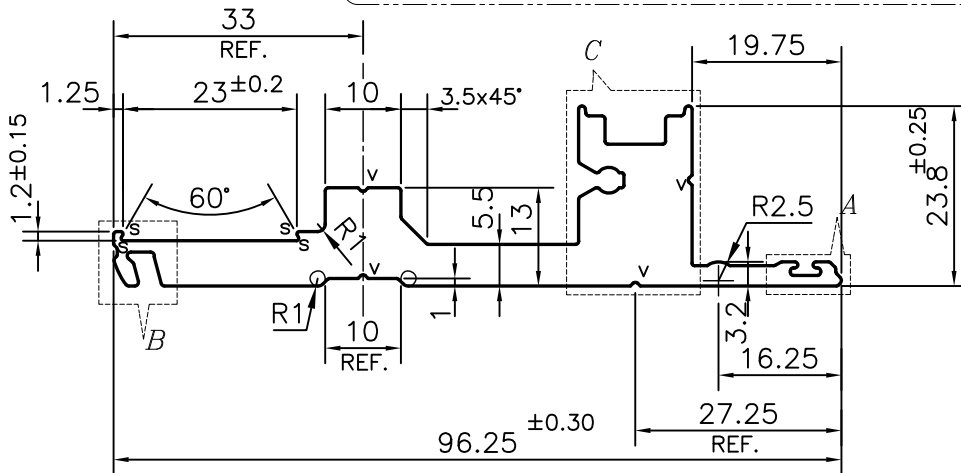
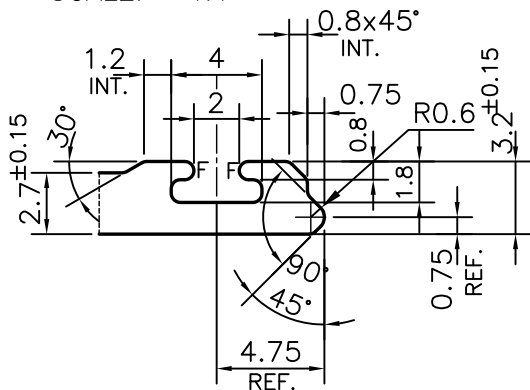

DETAIL OF "A"  
SCALE:- 3:1

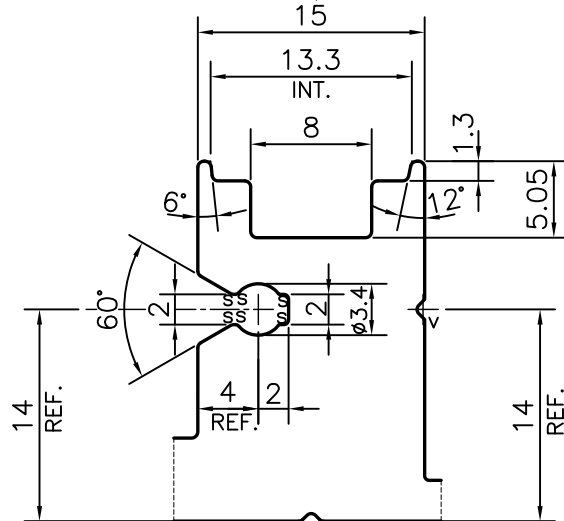

DETAIL OF "C"  
SCALE:- 2:1

V = VEE GROOVE 0.5x90° (4 PLACES)  
S = RADIUS 0.3 mm. (14 PLACES)  
X = RADIUS 0.5 mm. (3 PLACES)  
F = FULL RADIUS (2 PLACES)



SYMBOL OF QUALITY  
AN ISO 9001 COMPANY

**JINDAL ALUMINIUM LTD.**  
BANGALORE-560073 (INDIA)

	NAME	DATE
DRAWN	PARVESH	02-03-2013
CHECKED		
APPROVED	S.S.GARG	18-03-2013
SCALE		1:1
AREA mm <sup>2</sup>		753.335
PERIMETER mm.		289.361
WEIGHT kg/m		2.034
DRAWING No.	SECTION No.	
P-12486-2	-	
E0097	E0097	

1. ALL DIMENSIONS ARE IN mm.
2. ROUND OFF ALL SHARP CORNERS WITH 0.40 mm.
3. TOLERANCES WILL BE AS PER BS:EN-12020-2 , UNLESS OTHERWISE SPECIFIED

PARTY'S NAME	DORMA INDIA PVT. LTD., CHENNAI
PARTY'S DRAWING No.	AS PER Auto CAD DRAWING
ALLOY & TEMPER	6060 T66
DESCRIPTION	MISC. SECTION