

P-12529-1

E0101

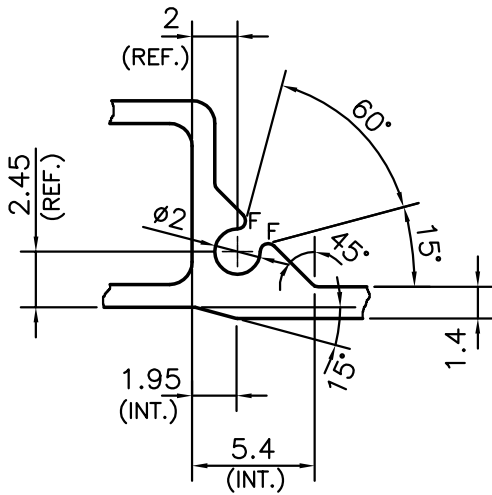
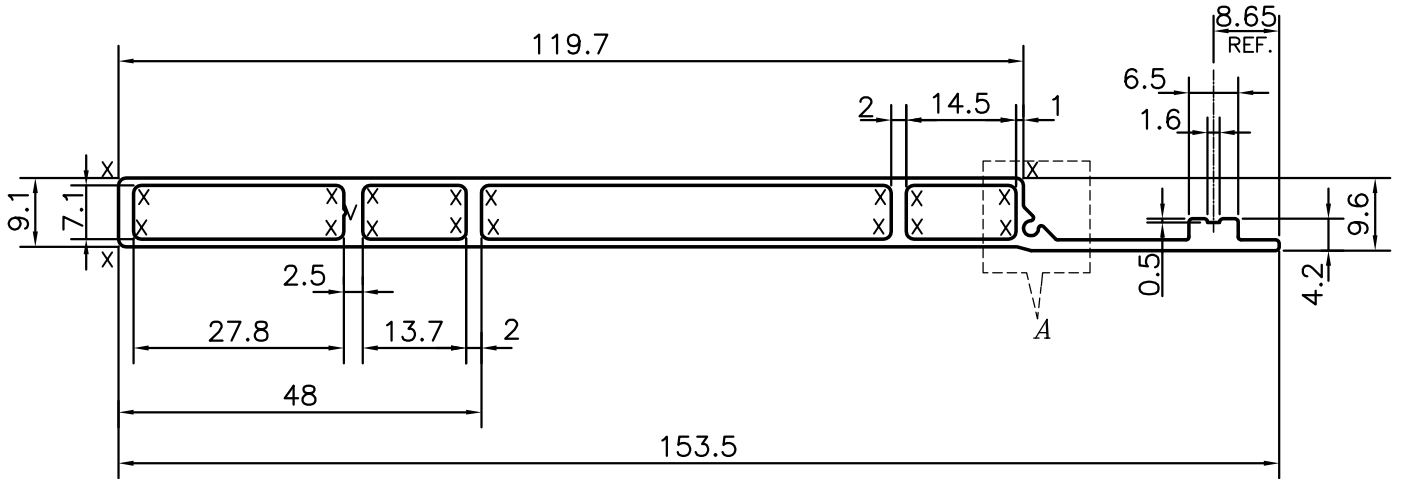

DETAIL OF "A"
SCALE 3:1

X = RADIUS 1 mm. (19 PLACES)
F = FULL RADIUS (2 PLACES)
V = VEE GROOVE 0.3x90° (1 PLACE)



SYMBOL OF QUALITY
AN ISO 9001 COMPANY

JINDAL ALUMINIUM LTD.
BANGALORE-560073 (INDIA)

	NAME	DATE
DRAWN	SRIVATHSA	13-03-2013
CHECKED		
APPROVED	S.S.GARG	26-03-2013
SCALE		1:1
AREA mm ²		380.086
PERIMETER mm.		331.544
WEIGHT kg/m		1.026
DRAWING No.	SECTION No.	
P-12529-1	-	
E0101	E0101	

1. ALL DIMENSIONS ARE IN mm.
2. ROUND OFF ALL SHARP CORNERS WITH 0.40 mm.
3. TOLERANCES WILL BE AS PER IS:6477-1983, UNLESS OTHERWISE SPECIFIED

PARTY'S NAME	YAMUNA ENTERPRISES, AHMEDABAD
PARTY'S DRAWING No.	AS PER SAMPLE & REQUIREMENT
ALLOY & TEMPER	HE9 WP
DESCRIPTION	TEXTILE SECTION