

P-12412

S3657

E0103

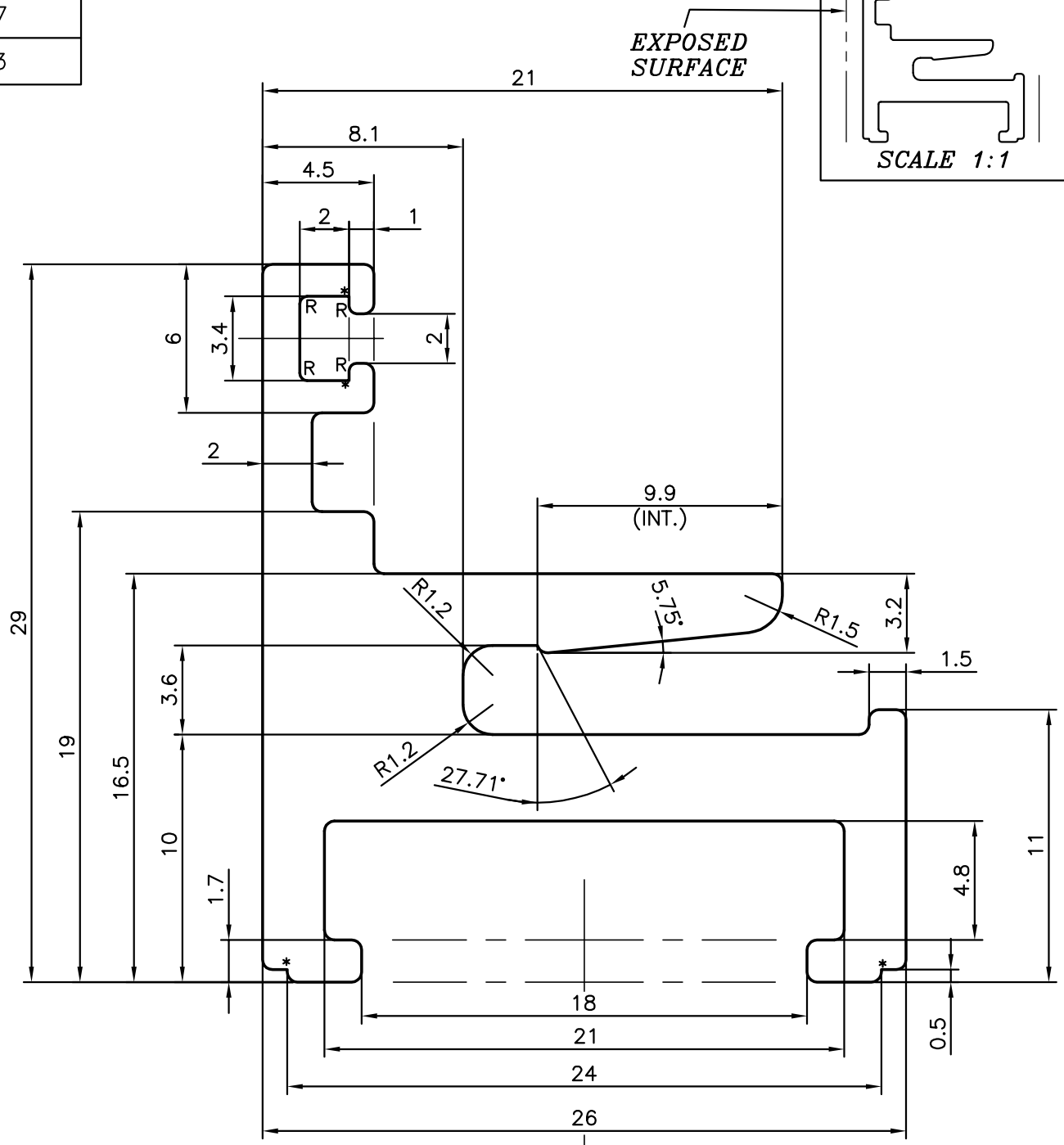

R = 0.30 mm RADIUS (4 PLACES)
 * = SHARP EDGES (4 PLACES)



SYMBOL OF QUALITY
 AN ISO 9001 COMPANY

JINDAL ALUMINIUM LTD.
 BANGALORE-560073 (INDIA)

	NAME	DATE
DRAWN	SRIVATHSA	03-01-2013
CHECKED		
APPROVED	S.S.GARG	11-02-2013
SCALE		4:1
AREA mm ²		254.95
PERIMETER mm.		163.781
WEIGHT kg/m		0.688
DRAWING No.	SECTION No.	
P-12412	-	
S3657	S3657	
E0103	E0103	

1. ALL DIMENSIONS ARE IN mm.
2. ROUND OFF ALL SHARP CORNERS WITH 0.40 mm.
3. TOLERANCES WILL BE AS PER BS:EN-12020-2, UNLESS OTHERWISE SPECIFIED

PARTY'S NAME	DORMA INDIA PVT.LTD., CHENNAI
PARTY'S DRAWING No.	168D01
ALLOY & TEMPER	6060 T6
DESCRIPTION	MISC. SECTION