

P-13167

E0122

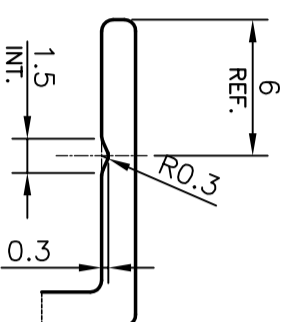
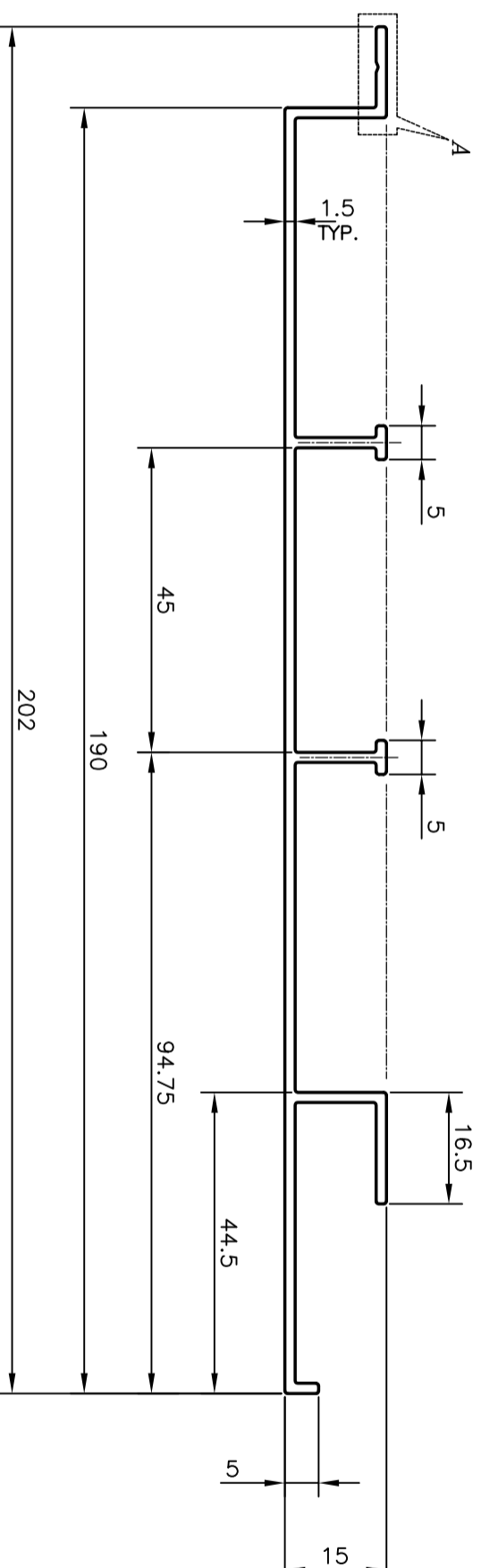

TOLERANCES ON OVERALL WIDTHS & WIDTHS ACROSS FLATS OF BARS, & REGULAR SECTIONS

UPTO 6.40mm - ±0.20	UPTO 32.0mm - ±0.38	UPTO 120.0mm - ±0.85
UPTO 10.0mm - ±0.23	UPTO 50.0mm - ±0.46	UPTO 160.0mm - ±1.02
UPTO 12.0mm - ±0.25	UPTO 60.0mm - ±0.53	UPTO 200.0mm - ±1.14
UPTO 16.0mm - ±0.28	UPTO 80.0mm - ±0.69	UPTO 250.0mm - ±1.40
UPTO 25.0mm - ±0.30	UPTO 100.0mm - ±0.75	UPTO 300.0mm - ±1.65



JINDAL ALUMINIUM LTD.
BANGALORE-560073 (INDIA)

DRAWN NAME: PARYESH
DATE: 02-11-2013

1. ALL DIMENSIONS ARE IN mm.
2. ROUND OFF ALL SHARP CORNERS WITH 0.40 mm.
3. TOLERANCES WILL BE AS PER IS:3965-1981, UNLESS OTHERWISE SPECIFIED

CHECKED
APPROVED S.S.GARG
SCALE: 1:1

PARTY'S NAME: RADHE KRISHNA GLASS & ALUM., SURAT

AREA: 421.87 mm²

PARTY'S DRAWING No.: AS PER DRAWING

PERIMETER: 560.618 mm

ALLOY & TEMPER: HE9 WP

WEIGHT: 1.139 kg/m

DESCRIPTION: TRANSPORT MISC. SECTION-EXTERNAL PENAL

DRAWING No.: P-13167
SECTION No.: E0122