

P-12856-1

E0132

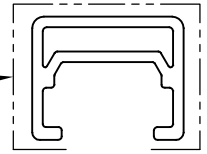

SCALE 1:1

EXPOSED SURFACE

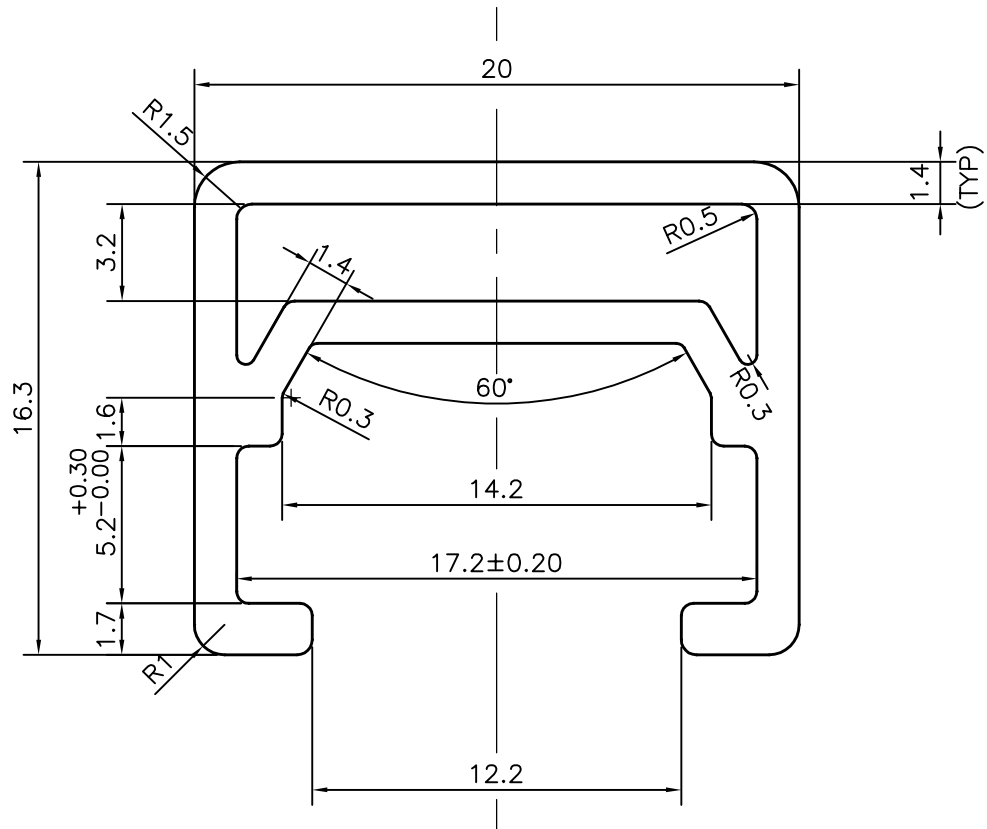

PLEASE NOTE:  
TOLERANCE GIVEN AS PER BS:EN:755-9

TOLERANCE CHART CD = CIRCUMSCRIBING CIRCLE

DIMENSION	CD ≤ 100	100 < CD ≤ 200	200 < CD ≤ 300	300 < CD ≤ 500
UPTO 10mm	±0.25	±0.30	±0.35	±0.40
10.0 - 25.0	±0.30	±0.40	±0.50	±0.60
25.0 - 50.0	±0.50	±0.60	±0.80	±0.90
50.0 - 100	±0.70	±0.90	±1.10	±1.30
100 - 150	-	±1.10	±1.30	±1.50
150 - 200	-	±1.3	±1.50	±1.80
200 - 300	-	-	±1.70	±2.10
300 - 450	-	-	-	±2.80



SYMBOL OF QUALITY  
AN ISO 9001 COMPANY

**JINDAL ALUMINIUM LTD.**  
BANGALORE-560073 (INDIA)

	NAME	DATE
DRAWN	SRIVATHSA	19-07-2013
CHECKED		
APPROVED	S.S.GARG	09-12-2013

- ALL DIMENSIONS ARE IN mm.
- ROUND OFF ALL SHARP CORNERS WITH 0.40 mm.
- TOLERANCES WILL BE AS PER BS:EN-755-9 , UNLESS OTHERWISE SPECIFIED

SCALE	4:1
AREA mm <sup>2</sup>	108.327
PERIMETER mm.	97.726
WEIGHT kg/m	0.292

PARTY'S NAME HAFELE INDIA PVT LTD., MUMBAI

PARTY'S DRAWING No. PR1970021A

ALLOY & TEMPER 6060 T6

DESCRIPTION MISC. SECTION

DRAWING No.	SECTION No.
P-12856-1	-
E0132	E0132