

P-13752

E0170

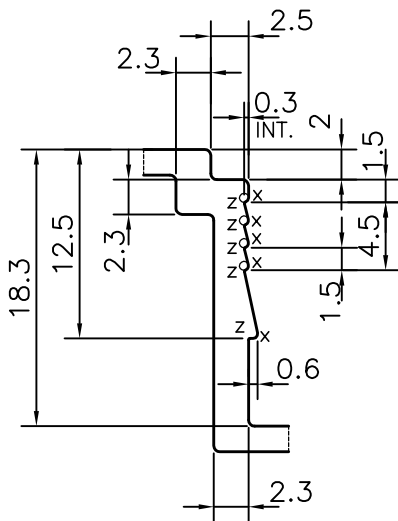

DETAIL OF "B"
SCALE 2:1

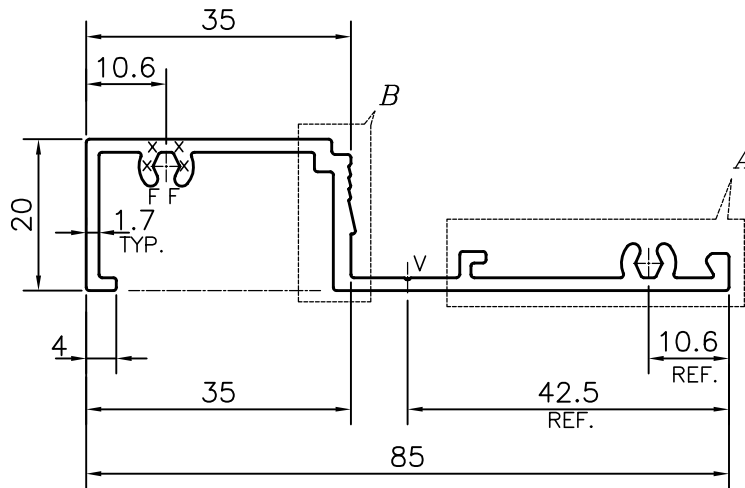
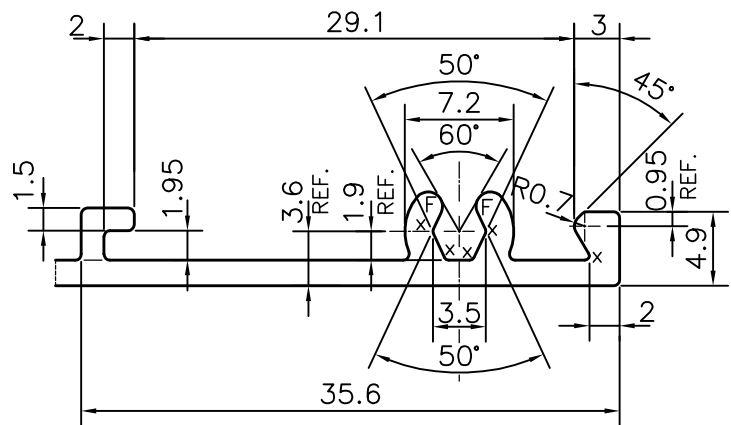

DETAIL OF "A"
SCALE 2:1

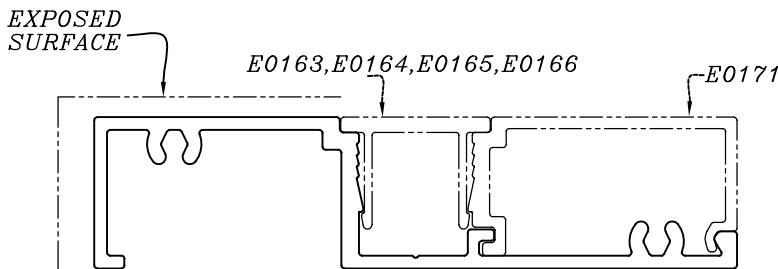

- X = RADIUS 0.3 mm. (14 PLACES)
- Z = RADIUS 0.1 mm. (5 PLACES)
- V = VEE GROOVE 0.3x90° (1 PLACE)
- F = FULL RADIUS (4 PLACES)

TOLERANCES ON OVERALL WIDTHS & WIDTHS ACROSS FLATS OF BARS, & REGULAR SECTIONS

UPTO 6.40mm - ±0.20	UPTO 32.0mm - ±0.38	UPTO 120.0mm - ±0.85	1. STRAIGHTNESS=1.7mm/M 2. TWIST=1.7mm/M 3. ANGULARITY= ±2° 4. FLATNESS =0.007xWIDTH
UPTO 10.0mm - ±0.23	UPTO 50.0mm - ±0.46	UPTO 160.0mm - ±1.02	
UPTO 12.0mm - ±0.25	UPTO 60.0mm - ±0.53	UPTO 200.0mm - ±1.14	
UPTO 16.0mm - ±0.28	UPTO 80.0mm - ±0.69	UPTO 250.0mm - ±1.40	
UPTO 25.0mm - ±0.30	UPTO 100.0mm - ±0.75	UPTO 300.0mm - ±1.65	



SYMBOL OF QUALITY
AN ISO 9001 COMPANY

JINDAL ALUMINIUM LTD.
BANGALORE-560073 (INDIA)

	NAME	DATE
DRAWN	PARVESH	18-07-2014
CHECKED		
APPROVED	S.S.GARG	24-07-2014
SCALE		1:1
AREA mm ²		275.224
PERIMETER mm.		298.699
WEIGHT kg/m		0.743
DRAWING No.	SECTION No.	
P-13752	-	
E0170	E0170	

1. ALL DIMENSIONS ARE IN mm.
2. ROUND OFF ALL SHARP CORNERS WITH 0.40 mm.
3. TOLERANCES WILL BE AS PER IS:3965-1981, UNLESS OTHERWISE SPECIFIED

PARTY'S NAME	SURFACES, BANGALORE
PARTY'S DRAWING No.	AS PER AUTOCAD DRAWING & REQUIREMENT
ALLOY & TEMPER	HE9 WP
DESCRIPTION	ARCHITECTURAL SECTION