

P-13753

E0171

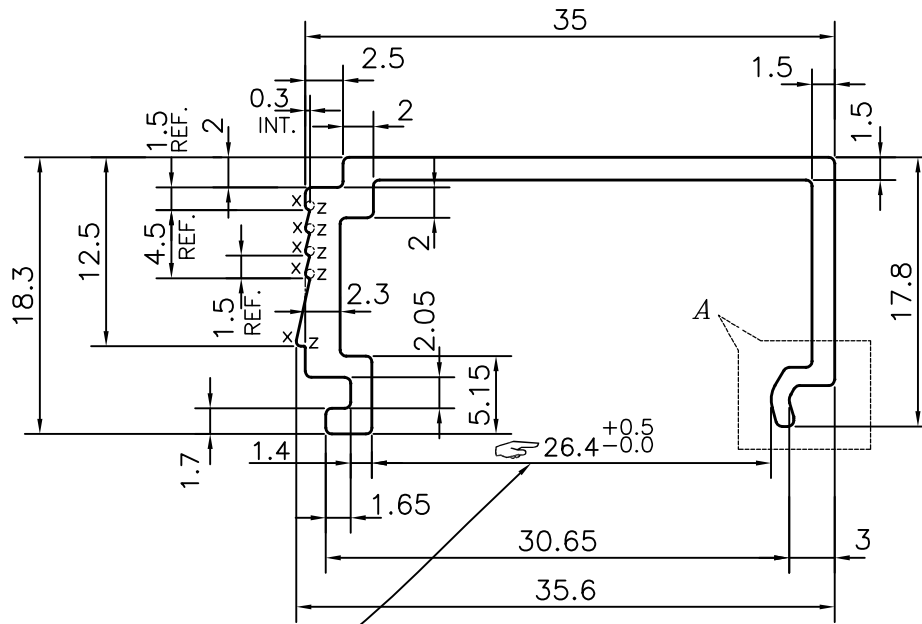

FOR INTERNAL Q/A CHECK

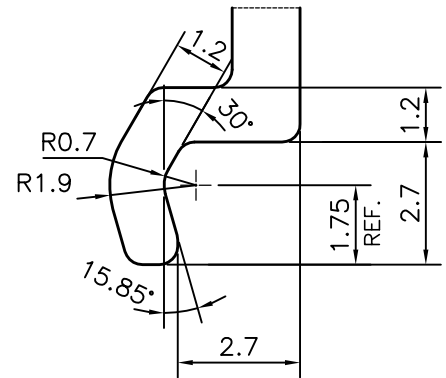
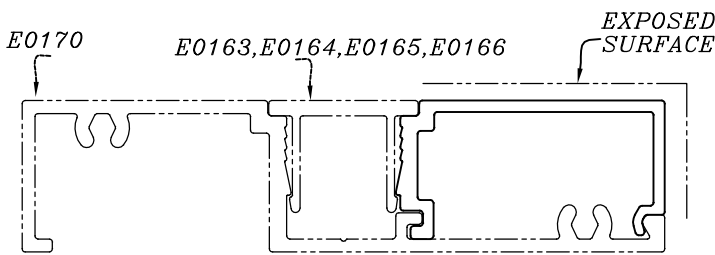

DETAIL OF "A"
SCALE 6:1



SCALE: - 1:1

X = RADIUS 0.3 mm. (5 PLACES)
Z = RADIUS 0.1 mm. (5 PLACES)

TOLERANCES ON OVERALL WIDTHS & WIDTHS ACROSS FLATS OF BARS, & REGULAR SECTIONS

UPTO 6.40mm - ±0.20	UPTO 32.0mm - ±0.38	UPTO 120.0mm - ±0.85	1. STRAIGHTNESS=1.7mm/M 2. TWIST=1.7mm/M 3. ANGULARITY= ±2° 4. FLATNESS =0.007xWIDTH
UPTO 10.0mm - ±0.23	UPTO 50.0mm - ±0.46	UPTO 160.0mm - ±1.02	
UPTO 12.0mm - ±0.25	UPTO 60.0mm - ±0.53	UPTO 200.0mm - ±1.14	
UPTO 16.0mm - ±0.28	UPTO 80.0mm - ±0.69	UPTO 250.0mm - ±1.40	
UPTO 25.0mm - ±0.30	UPTO 100.0mm - ±0.75	UPTO 300.0mm - ±1.65	



SYMBOL OF QUALITY
AN ISO 9001 COMPANY

JINDAL ALUMINIUM LTD.
BANGALORE-560073 (INDIA)

	NAME	DATE
DRAWN	PARVESH	18-07-2014
CHECKED		
APPROVED	S.S.GARG	24-07-2014

- ALL DIMENSIONS ARE IN mm.
- ROUND OFF ALL SHARP CORNERS WITH 0.40 mm.
- TOLERANCES WILL BE AS PER IS:3965-1981, UNLESS OTHERWISE SPECIFIED

SCALE	2:1
AREA mm ²	120.378
PERIMETER mm.	148.707
WEIGHT kg/m	0.325

PARTY'S NAME	SURFACES, BANGALORE
PARTY'S DRAWING No.	AS PER AUTOCAD DRAWING & REQUIREMENT
ALLOY & TEMPER	HE9 WP
DESCRIPTION	ARCHITECTURAL SECTION-CLIP

DRAWING No.	SECTION No.
P-13753	-
E0171	E0171